

version 1.0

# 2018 Catalogue

 **major  
science**  
*Innovative Life Sciences Tools*





# Contents

## About Major Science

03-05

- ▣ Who We Are
- ▣ Our History
- ▣ Our Mission
- ▣ Our Vision
- ▣ Our Quality Policy
- ▣ Our Capabilities
- ▣ Current Areas Of Focus
- ▣ Our Values



## Bioprocessing Technology

06-17

- ▣ Bioprocess Downstream 07
  - High Speed Tubular Centrifuge
- ▣ Cultivation Incubator 07-08
  - Winpact Shaker
  - Winpact Shaking Incubator
- ▣ Bioreactor / Fermentor 09 -17
  - Laboratory Bioreactor / Fermentor
  - Optional Devices and Accessories
  - SIP Fermentation System (Pilot & Production)

## Life Sciences Research

18-97

### ■ Electrophoresis and Related Products

18-49

- Power Supply
- Nucleic Acid Electrophoresis
- Protein Electrophoresis
- Blotting
- Special Application
- MS Pipette

### ■ Amplification / PCR

50-52

- Thermal Cycler
- PCR Workstation

### ■ Gel Documentation System

53-65

- Imaging System
- Transilluminator

### ■ Blue Light Technology

66-73

- SafeBlue System
- Blue Light Illuminator

### ■ Mixer / Temperature Control

74-94

- Dry Bath Incubator
- Dry Bath Block / Beads
- Incubator
- Shaker
- Stirring Water Bath

### ■ Peristaltic Pump

95-97

- Digital Peristaltic Pump
- Dual and Tetrad Peristaltic Pump

## Chemical Engineering

98-100

### ■ Thermostirrer

99-100

- Thermostirrer
- Remote Thermostirrer Module



## Fermentation and Cell Cultivation Technology

Winpact is a product brand under Major Science, which provides a comprehensive and innovative line of cultivation products designed for different cell culture experiments and applications. It comes at a benchtop scale and has a large, color touch-screen panel with a user-friendly interface. Its distinctive functions include various programming operations to control the pump speed, pH levels, temperature, and more. The Winpact Fermentation System comes equipped with a full connection device to connect to any PC for real-time recording and environment control within the vessel.

## About Major Science

### Who We Are

Founded in 1994 by a team of experienced engineers as well as up-and-coming design specialists, Major Science designs, manufactures, and markets laboratory equipment that supports scientific research in life sciences laboratories. Headquartered in Saratoga, California, Major Science provides laboratory products and quality services to biotechnology companies, academic institutions and government research labs across the world.

Major Science is consistently delivering cutting-edge instruments for the bio-industry that cover nearly all of your laboratory needs. We provide the Winpact family which is the state-of-the-art fermentor and bioreactor for the fermentation and cell cultivation system. The Winpact product family offers a wide range of fermentation systems and includes many of the most widely applied bench top-sized instruments for the life sciences field. In addition, we also offer innovative general instruments for all of your laboratory needs. Our general instrument product line includes Electrophoresis and Related Products, Amplification / PCR, Gel Documentation System, Blue Light Technology, Mixer / Temperature Control and Peristaltic Pump.

Major Science conducts business via our global distribution partners who also serve as our main sales force. These strategically-located partners ensure that Major Science supplies top-quality products, services, and support to all of our customers in any region of the globe. Products from Major Science are produced under international quality standards and specifications that excel in performance.

For more information, please feel free to contact us.

[www.majorsci.com](http://www.majorsci.com)

[info@majorsci.com](mailto:info@majorsci.com)

### Our History

- 1994 Major Science founded as a biotechnology instrument distributor and provide engineering service in life sciences field.
- 1996 Began to sell Major Science branded general instruments.
- 2000 Announced our Winpact fermentation and cell cultivation product lines.
- 2005 Built up global awareness.
- 2008 Founded branch offices overseas.
- 2013 Accredited to SGS ISO 9001:2008
- 2017 Accredited to SGS ISO 9001:2015







### Our Mission

Major Science is devoted to create life sciences research instruments through quality and innovation. Our mission is to deliver integrated laboratory solutions to our customers and distribution partners through collaborative teamwork, thoughtful innovation, practical efficiency and outstanding service.

### Our Vision

Major Science is devoted to serving customers in the scientific community across the globe, which means we are constantly progressing toward further innovation and working for wider applications for our products.

Creating innovative cell cultivation solutions is among one of our highest priorities. For the Winpact family product lines, we will be adding vessels that are bigger and smaller in size, as well as pilot and production scale vessels. Furthermore, we are developing the means to create connections from multiple cell culture vessels in different conditions to a single controller. In addition, Major Science is expanding on the cell cultivation line with more optional devices that can be integrated with our current systems. These expansion includes various vessel types, parts, accessories, and sub-systems. We will also embed the use of disposable systems that function with plastic instead of glass vessels.

### Our Quality Policy

As of January, 2013. Major Science is accredited to the SGS ISO 9001:2008 compliance.

Major Science strives to achieve high standard for customer satisfaction, we promise to always improve our quality by means of research and development, as well as embrace any challenge come forth within.

### Our Capabilities

- Innovative product design from our in-house R&D team
- Flexible production schedules
- ETL certified manufacturing facility
- CE and 3rd party certification
- OEM/ODM production experiences with leading companies
- Global marketing and product support
- Worldwide liability insurance across all product lines

### Current Areas Of Focus

At Major Science, we are developing a comprehensive network of innovative products and services. We are continuously broadening our scope for people researching life sciences to provide an effective source of instrumentation.

#### Bioprocessing Technology

##### Bioreactor/Fermentors

Innovative SIP pilot and lab fermentation system suitable for all of your cell culture and fermentation engineering purposes

##### Cultivation Incubator

The ultimate bench-top model provide the stability and durability for all your fermentation and incubation needs

##### Bioprocess Downstream

The High-Speed Tubular Centrifuge offers high-performance centrifugal phase separation solution for a variety of applications in the industries

#### Life Sciences Research

##### Electrophoresis and Related Products

Provide excellent equipment for all of your nucleic acid and protein separation experiment

##### Amplification/PCR

An automated instrument series designed for running polymerase chain reaction experiments

##### Gel Documentation System

Simple and innovative gel imaging systems and quantification software

##### Blue Light Technology

A comprehensive safe and environmental friendly blue light technology product range for real time gel observation during/after electrophoresis and gel treatments

##### Mixer/Temperature Control

A series of simple, compact and innovative incubators with shaking mechanisms for all of your application needs

##### Peristaltic Pump

Quality digital peristaltic pumps are suitable for various of your application needs

#### Chemical Engineering

##### Thermostirrer

Major Science thermostirrer series are equipped with built-in stirrers on the bottom of each well combined with excellent temperature control. A long motor durability product for chemical compound synthesis, combinatorial chemistry, sample concentration, denaturation, derivatization, enzyme analysis and process optimization



# Our Values

## Professionalism

Major Science has its own professional Research & Development team of scientists and product specialists that are further supported by an outperforming sales team. We integrate laboratory experiences with customers' feedback in order to ensure the best quality of products and services from the placing of your order to its delivery.



### Serving our customers

Major Science cares about what you care and we are dedicated to gaining your confidence. Major Science dedicated in providing best efforts to all of our customers' needs whether they are customized products or technical supports or others.

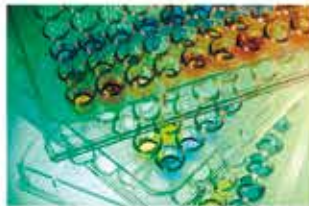

### Staying Green, protecting mankind

Major Sciences collaborate with our global distributors to distribute our products to every corner of the world, we take pride and corporate social responsibility of being a good global citizen in ensuring the protection of our environment.



### User-friendly Instruments

Major Science offers easy-to-operate and convenient instruments in the world of biotechnology. We provide simple and intuitive methods such as touch-screen and keypads for different applications that are easy to navigate and operate.



### Innovation

Major Science is determined to use not only our expertise in the laboratory, but also the prior experience of our users and employees to breakthrough with the future generations of our cultivation products along with the advancement of all our other products.





# All about Winpact Fermentation and Cell Cultivation System

Winpact serves as our major product brand under Major Science. We strive to create innovative fermentors and fermentation bioreactors for all your cell cultivation and fermentation needs.

## Bioprocessing Technology

### ▣ Bioprocess Downstream 07

High Speed Tubular Centrifuge

### ▣ Cultivation Incubator 07-08

Winpact Shaker  
Winpact Shaking Incubator

### ▣ Bioreactor / Fermentor 09-17

➤ Laboratory Bioreactor / Fermentor  
Winpact Parallel System  
Winpact Benchtop SIP Systems  
Winpact One System  
Winpact Evo System  
Winpact Solid State Fermentation System

➤ Optional Devices and Accessories

➤ SIP Fermentation System (Pilot & Production)  
SIP Fermentation System



## Winpact Mass Flow Controller

### FS-O-MF series

The gas composition is important for microorganism/cell culture. To maintain different gases at a defined flow rate during bioprocesses, Winpact Mass Flow Controller can provide accurate and stable flow measurement and control.

Mass flow controller (MFC) is a precise device which is used to control a specific type of liquid or gas at a particular range of flow rates. MFC is composed of block, flow-splitter or bypass, sensor, printed circuit board (PCB), and control valves. When gas flows into MFC, the sensor will detect its real volume and compare with the setting value (standard value), if the detection value is lower than setting value, the inner control valve will open slightly for increasing the input flow; conversely, if the detection value is higher than the setting value, the inner control valve will close slightly for reducing the input flow, for this reason, MFC is able to adjust the flow automatically and more accurately.

Besides this, overlay (headspace aeration) control is also useful for fermentation process. Winpact Mass Flow Controller also can sparge different gases into the reactor through the headspace and the sparger at the same time.

Now, Winpact Mass Flow Controller could be integrated into Winpact Fermentation system and achieve operational efficiency and creative stable environment in culture conditions.

#### Features

- Affordable price
- Self-made, high quality accurate gas control guarantee



\*For more information, please contact your local distributors.



# High Speed Tubular Centrifuge

## FS-O-TC series

The High-Speed Tubular Centrifuge offers high-performance centrifugal phase separation solution for a variety of applications in the industries of biopharma, Chinese herbal therapy, dietary supplements, food & beverage and chemical engineering. This powerful but compact machine can separate as small as 1µm micro-sized particles, even highly corrosive material.

### Design Features and Benefits

- Simple and robust design
- Suitable for using corrosive materials
- Small footprint
- Separation of small particles (to 1µm)
- High performance
- Compact design

### Typical Applications

- Separation of viruses and bacteria
- Classification of biotechnological solutions
- Production of gamma-globulin
- Separation and clarification of lubricating oils, greases and solvents
- Concentration of essential oils
- Purification of fish oils
- Dehydration of varnishes and lacquers
- Clarification of fruit juices
- Chemical engineering
- Bio-pharmaceutical production



FS-O-TC

### Specification

Cat. No.	FS-O-TC01	FS-O-TC02
Bowl Diameter	3" (75mm)	4.1" (105mm)
Bowl Cubage (L)	2	6
Material Of Bowl	316 stainless steel	316 stainless steel
Rotary Drum Of Bowl	17.7" (450mm)	29.2" (742mm)
Max. Speed (rpm)	20,000±500	16,000±500
Max. RCF (xg)	16,700	15,050
Pass Water Capacity (T/h) *	0.2	1.2
Product (L/h) **	20-100	100-900
Motor Power (kW)	1.2	3
Rated Voltage (V)	AV380	AV380
Weight	Approx. 551.2lb (250kg)	Approx. 1102.3lb (500kg)
Dimension (WxLxH)	26"x15.4"x47.2" (660×390×1200mm)	26.8"x17.7"x62.2" (680×450×1580mm)
Height Of Outlet	24.8" (630mm)	34.6" (880mm)
ID Of Inlet	Ø0.5" (12mm)	Ø0.5" (12mm)
ID Of Outlet	Ø1.3" (32mm)	Ø1.5" (38mm)

\*T/h :Ton/hour

# Winpact Shaker

## WS-200 series



CE WS-200 / WS-201

The WS-200 shaker is developed to offer an integrated solution for every mixing requirement. With a large 18.1"X18.1" platform and a wide selection of labware holders, this versatile machine can accommodate five 2L flasks or any combination of labwares up to 30kg. This powerful machine is equipped with a maintenance-free brushless motor that permits the device to operate noiselessly even at 500rpm under programmable mode of operation or continuous mode up to 999hr.

### Features

- Various speed settings from 20-500rpm
- Equipped with a robust brushless DC motor for economical and noiseless operation
- Two modes of operation available: programmable or continuous
- Versatile accessories available for advanced culturing solutions
- Auto detection and power shutdown to platform weight imbalance or belt breakage

### Specification

Cat. No.	WS-200	WS-201
Description	Winpact Orbital Shaker (universal platform included)	Winpact Orbital Anti-moistured Shaker (universal platform included)
Platform Size	Approx. 18.1"x18.1" (460x460mm)	
Shaking Orbit	Approx. 0.7" (19mm)	
Speed Range	20-500rpm	
Speed Increment	1rpm	
Timer	999 (hr): 59 (min) / Continuous	
Display	3.5" Color TFT LCD screen	
Dimension (WxLxH)	Approx. 20.5"x24.4"x8.3" (520x620x210mm)	
Rated Voltage	100-240V~, 50 / 60Hz, 2A	
Loading Capacity *	Approx. 500rpm: 11" (5kg), 250rpm: 66.1" (30kg)	
Anti-moistured	N/A	Yes
Weight	Approx. 88.2lb (40kg)	

\* Different flask will reduce the maximum speed.

\* Accessories information, please refer to Page 8.



# Winpact Shaking Incubator



SI-200

Major Science is introducing our newly innovated Winpact series shaking incubator. It provides you the stability and durability for all your fermentation and incubation needs. The system incorporate multi-safety features to put you at your ease of mind.

## Features

- Special designed drainage channel protects the motor and inner circuitry from accidental spills
- Multiple early error-detection mechanisms ensure operators' safety and completeness of experiment despite malfunction
- Lab-proven superior temperature uniformity
- A wide selection of racks, holders, sticky pads and accessories provides all-ranged compatibility to cell cultivation labwares
- Automatic system shutdown in the event of system over-heating
- Sensitivity adjustable G-sensor with warning embedded for imbalance weight detection
- Programmable or continuous mode for personnel operation
- Brushless DC motor provides long and quiet operation, durable and maintenance-free usage
- Hermetic chamber design significantly reduces operation noise and enhances precise temperature control
- 2-point temperature calibration ensures high temperature performance



A spare air/gas inlet to create particular environment for specific kinds of cell/microbial

SI-200



## Specification

Cat. No.	SI-200
Platform Size	Approx. 18.1"x18.1" (460x460mm)
Shaking Orbit	Approx. 0.7" (19mm)
Speed Range	20-500rpm
Speed Increment	1rpm
Communication Port	RS-485
External Temperature Probe	PT-100
Heating Temperature Range	Ambient +5°C to 65°C
Power	600W
Temp Accuracy And Uniformity	± 0.25°C at 37°C
Timer	999 (hr) : 59 (min) / Continuous
Display	3.5" Color TFT LCD screen
Dimension (WxLxH)	Approx. 23.2"x32.3"x20.9" (590x820x530mm)
Weight	Approx. 154.3lb (70kg)
Rated Voltage	110 / 220V~, 50 / 60Hz, 6.3A



## Accessories



Universal platform  
Cat. No.: SI-200-01



Adjustable angle tube rack (33x15ml)  
Cat. No.: SI-200-02  
\*tube not included



Adjustable angle tube rack (16x50ml)  
Cat. No.: SI-200-03



Universal spring rack  
Cat. No.: SI-200-04



Sticky pad platform  
Cat. No.: SI-200-05



Universal cushioned crossbar  
Cat. No.: SI-200-06



Microplate holders  
Cat. No.: SI-200-07  
(platform not included)



Flask holder  
Cat. No.: SI-200-08-13

## Racks and Tray

\* Different flask will reduce the maximum speed.

Cat. No.	Product Description	Max. Platform Capacity
SI-200-01	Universal platform	1
SI-200-02	Adjustable angle Tube Rack ( 33x15ml )	4
SI-200-03	Adjustable angle Tube Rack ( 16x50ml )	4
SI-200-04	Universal Spring Rack	2
SI-200-05	Sticky Pad platform	1
SI-200-06	Universal Cushioned Crossbar platform	1
PPL-04-SI-SI-200-3	Sticky pad 200x200mm	4

## Microplate and flask holder

Cat. No.	Product Description	Max. Platform Capacity
SI-200-07	Microplate holder	9
SI-200-08	Flask holder, 50ml	52
SI-200-09	Flask holder, 125ml	25
SI-200-10	Flask holder, 250ml	25
SI-200-11	Flask holder, 500ml	16
SI-200-12	Flask holder, 1000ml	9
SI-200-13	Flask holder, 2000ml	5

# Winpact Parallel System

## FS-05 Series

The Winpact Parallel Fermentation System is the ultimate and true parallel system for your parallel experiment. Whether you need to run two identical experiment or different experiment at the same time, the duo heating system allows you to run two thermostat heating, two dry heating or one thermostat and one dry heating simultaneously. The state of the art design is constructed with the upmost versatility for you to operate any vessel type and size in any combination you like. The remote software can control up to 16 vessels for true parallel operation.

- Duo heating system, thermostat and dry heating combined in one
- True Parallel System, 1 controller controls 2 vessels
- Interchangeable 5 types of autoclavable glass vessel
- Control up to 8 systems from a single interface
- Compatible with microbial and cell culture applications
- Intuitive user interface for short learning time
- Ethernet communication with Winpact SCADA software, and IP addressing
- Compatible with vessel volume from 0.5L to 20L
- Full selection of optional devices available
- Auto vessel angle control mechanism for solid state vessel
- Solid state vessel performs 0° - 90° rotation, and 120° for harvest

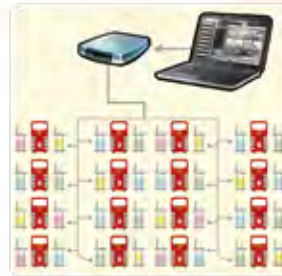

Remote control software connects up to 16 systems (total 32 vessels) at the same time via PC



Newly developed Winpact interface for easy operation



# Winpact Benchtop SIP Systems FS-05S / FS-07S

The Winpact Benchtop Parallel SIP Fermentation System is the newest addition to our range of controller systems. With an upgrade modification to the original Winpact Parallel System, the new FS-05S controller is able to adapt and control various combinations of vessel types. You can pair it with one glass vessel and one stainless steel vessel, two glass vessels, or even two stainless steel vessels. The new controller includes the following features:

- Semi-automatic sterilization-in-place for stainless steel vessels
- Stainless steel vessel compatible (max. volume: 30L)
- Ability to adapt to two different vessel types: stainless steel vessel or glass vessel, mix-and-match
- Vessels can be operated simultaneously or separately

\*Some modification to fit the demand including: circulation system, heat exchanger, motor board, probe connection, etc.

\*FS-07S, which can control either one glass vessel or one stainless steel vessel is also coming soon. Glass vessel that is compatible with FS-07 is also compatible with FS-07S. Available stainless steel vessel for FS-07S ranges from 10L to 30L.

\*For more information, please contact your local distributors.



- ① Single wall dish bottom vessel, 1L
- ② Double jacketed dish bottom vessel, 3L
- ③ Single wall air lifter vessel, 5L
- ④ Double jacketed air lifter vessel, 5L
- ⑤ Single wall dish bottom vessel with heating blanket, 5L
- ⑥ Single wall plain bottom vessel with heating base unit, 10L
- ⑦ Double jacketed dish bottom vessel, 500ml
- ⑧ Stainless steel vessel, 10L
- ⑨ Solid State, 5L



# Winpact One System

## FS-06 Series

The most versatile, price and space saving fermentation system is now available from our Winpact fermentation product line-the Winpact One Fermentation System.

Winpact One is not only compact in size but also provides all the necessary tools as a standard instrument. The duo heating system allows you to choose any vessel type up to 10L for any application needs. The optional expansion module allows you to add additional devices to enhance the capability of the system. All necessities such as temperature, anti-foam, pH and DO probe are all included in the standard package.

- Duo heating system, thermostat and dry heating combined in one
- Most versatile and compact system on the market ((WxLxH) 250x510x500mm)
- Interchangeable 5 types of autoclavable glass vessel
- Control up to 16 systems from a single interface
- Compatible with microbial and cell culture applications
- Intuitive user interface for short learning time with multi-language support
- Ethernet communication with Winpact SCADA software, and IP addressing
- Expansion module available for system upgrade for optional devices



# Winpact Evo System

## FS-07 Series

Winpact Evo System is the one-side version of Winpact Parallel System yet offers cutting edge software. It retains all the great features from FS-05 such as duo heating system, 16-system control from a remote computer, 5 types of autoclavable glass vessel ranging from 0.5L to 20L. We also greatly enhanced the functionalities and capabilities of this newly developed controller, including the versatility to accommodate solid state system.

- Intuitive user-interface for short learning time with multi-language support
- Ethernet communication with Winpact SCADA software, and IP addressing
- Winpact EZScript software for advance fermentation process (optional)
- Control up to 16 systems from a single interface on external PC
- Duo heating system, thermostat and dry heating all combined in one
- Compatible with microbial and cell culture applications
- Interchangeable 5 types of autoclavable glass vessel
- Auto vessel angle control mechanism for solid state vessel
- Solid state vessel performs 0°- 90° rotation, and 120° for harvest

(FS-V-SA05P)

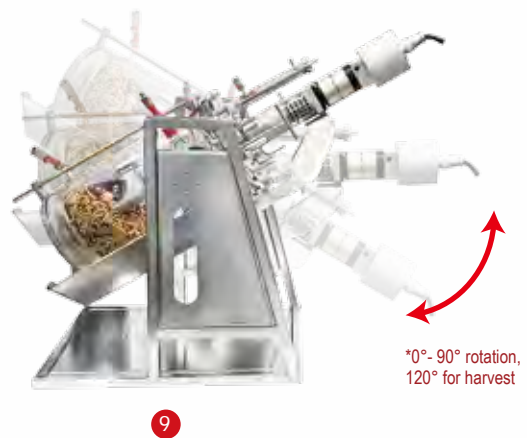

\*0°- 90° rotation,  
120° for harvest

\*For more information, please contact your local distributors.



- ① Single wall dish bottom vessel, 1L
- ② Double jacketed dish bottom vessel, 3L
- ③ Single wall air lifter vessel, 5L
- ④ Double jacketed air lifter vessel, 5L
- ⑤ Single wall dish bottom vessel with heating blanket, 5L
- ⑥ Single wall plain bottom vessel with heating base unit, 10L
- ⑦ Double jacketed dish bottom vessel, 500ml
- ⑧ Stainless steel vessel, 10L
- ⑨ Solid State, 5L

## Duo Heating Control: FS-05 / FS-06 / FS-07 series

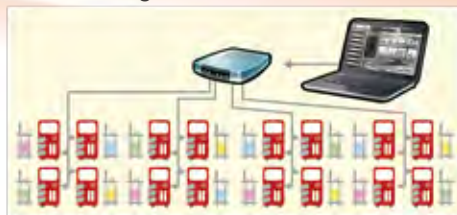

PC remote controlling software connects up to 16 systems

- These Winpact controllers can operate with all types of vessels
- Compatible with microbial and cell culture applications
- Intuitive user-interface for short learning curve with multi-language support
- Ethernet communication with Winpact SCADA software, and IP addressing



Control multi-vessel systems on one page.

## Controller Specification

Controller	Duo Heating Control ( FS-05, FS-06, FS-07 )					
Vessel	Double Jacketed (FS-V-A series)	Single Wall (FS-V-B series)	Air Lifter (FS-V-C series)	Single Wall with Heating Blanket (FS-V-B series)	Single Wall with Heating Base Unit (FS-V-D series)	Solid State (FS-V-SA05P)
Agitation Motor	Brushless motor	Brushless motor	N/A	Brushless motor	Brushless motor	Brushless motor
Impeller*	Rushton-type	Rushton-type	N/A	Rushton-type	Rushton-type	Multi-Type
Temp Range	5 °C above coolant to 60°C	5 °C above coolant to 60°C	5 °C above coolant to 60°C	5°C above coolant to 60°C	5°C above coolant to 90°C	5°C above coolant to 60°C
Vessel Size	500ml - 10L	1 - 10L	5L only, single or double jacketed	1 - 20L	3 - 10L	5L only
Speed Range	30-1,800rpm(500ml, 1L) 30-1,200rpm(3, 5L) 30-1,000rpm (10L)	30-1,800rpm(1L) 30-1,200rpm(3, 5L) 30-1,000rpm(10L)	N/A	30-1,800rpm(1L) 30-1,200rpm(3, 5L) 30-1,000rpm(10L) 30-700rpm(15, 20L)	30-1,200rpm(3, 5L) 30-1,000rpm(10L)	1-60rpm
Heating	Built-in heat exchanger			Heating blanket	Heating base unit	Built-in heat exchanger
Cooling	External chiller, automatic cooling water valve					
Aeration	Orifice ring sparger	Orifice ring sparger	PTFE micro sparger	Orifice ring sparger	Orifice ring sparger	Grounding port: shaft sparger
Grounding Port	No need	No need	Yes	No need	No need	No need
Application	Excellent for temperature sensitive and shear-force sensitive cells such as mammalian and insect cell culture	Great for aerobic or anaerobic microbial culture; suitable for plant cell and photosynthesis cell culture	Excellent for shear-sensitive cells; ideal for plant cells, fungal cells, algae cell and photosynthesis cell culture	Ideal for rapid temperature change aerobic and anaerobic microbial (bacteria and yeast) fermentation	Excellent for aerobic and anaerobic microbial (bacteria, yeast) culture, such as E.coli	Special for the culture of microbial in substrates with low water levels condition , generally suitable for fungi, such as filamentous fungi

\*The standard impeller is Rushton-type; pitched blade is available for cell culture user upon request.

## Winpact Controller Selection Guide

Model	FS-05	FS-06	FS-06 + FS-06EPM*	FS-07
Product Name	Winpact Parallel	Winpact One	Winpact One	Winpact Evo
Heating System	Duo heating			
Working Volume Range	500ml - 20L	500ml - 10L	500ml - 10L	500ml - 20L
Autoclavable Glass Vessels	Yes			
Interchangeable Vessels	All types			
Number Of Vessels Controlled Per Controller	2	1	1	1
Number Of Vessels Controlled Via Remote Software	Max 16			
Touchscreen Controller	10.4"	8"	8"	10.4"
Number Of Peristaltic Pumps	8	3	3	4
Gas Mixing Options	Available	No	Available, *	Available
Oxygen Enrichment	Available	No	Available, *	Available
Mass Flow Controller	Available	No	No	Available
Off Gas Analyzer	Available	No	No	Available
ORP Probe	Available	No	Available, *	Available
Lighting Module	Available	No	Available, *	Available
External Pump	Multiple	1 max.	2 max.	Multiple
Solid State	No	No	No	Available

\* Optional expansion module (FS-06-EPM) needed.

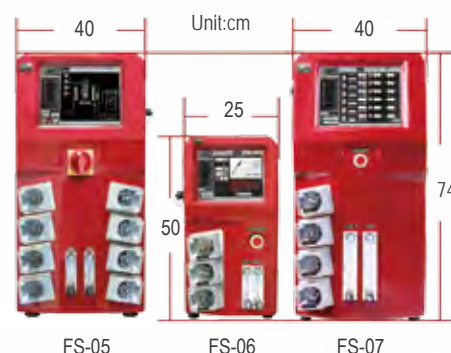

FS-05

FS-06

FS-07



	Vessel Type	Double Jacketed Dish Bottom Vessel (FS-V-A series)				
	Material	Borosilicate glass / 316L stainless steel for headplate and all fittings				
	Working Volume **	500ml	1L	3L	5L	10L
	Total Volume Δ	1L	1.5L	3.8L	6.8L	12.5L

	Vessel Type	Single Wall Dish Bottom Vessel (FS-V-B series)			
	Material	Borosilicate glass / 316L stainless steel for headplate and all fittings			
	Working Volume **	1L	3L	5L	10L
	Total Volume Δ	1.5L	3.8L	6.8L	12.5L

	Vessel Type	Air Lifter Vessel (FS-V-C series)			
	Material	Borosilicate glass / 316L stainless steel for headplate and all fittings			
	Working Volume **	5L single wall		5L double jacketed	
	Total Volume Δ	7L			

	Vessel Type	Single Wall Dish Bottom Vessel With Heating Blanket (FS-V-B series)					
	Material	Borosilicate glass / 316L stainless steel for headplate and all fittings					
	Working Volume **	1L	3L	5L	10L	15L	20L
	Total Volume Δ	1.5L	3.8L	6.8L	12.5L	18.7L	23.7L

	Vessel Type	Single Wall Plain Bottom Vessel With Heating Base Unit (FS-V-D series)		
	Material	Borosilicate glass / 316L stainless steel for headplate and all fittings		
	Working Volume **	3L	5L	10L
	Total Volume Δ	3.7L	6.7L	13.1L

	Vessel Type	Solid State (FS-V-SA05P)		
	Material	Borosilicate glass / 316L stainless steel for headplate and all fittings		
	Working Volume **	5L		
	Total Volume Δ	6.8L		

\*\* Suggested Max.

Δ Total volumes are approximate and may vary slightly.



No software purchase necessary  
Ethernet cable connection for remote control



\*PC and switch hub are not included



Multi-language operation interface (Russian language)

• Winpac \*\*EZScript software for advanced fermentation process(optional)

\*\* Winpac EZScript is a command software specifically designed with user-define programming capability to optimize and control of your process.



### Charting

Real-time data recording and exporting



### System Setup

Set up for optional devices



### Calibration

Easy sensor calibration with help menu



### Control / Manual

Perform manual, sequence or EZScript control(optional) of each parameter.



### Control / Sequence



### Pumps

Control speed, direction, total volume and flow rate

## Vessel Application

Application	Vessel	FS-V-A series	FS-V-B series	FS-V-C series	FS-V-B series	FS-V-D series	FS-V-SA05P
		Double Jacketed Dish Bottom Vessel	Single Wall Dish Bottom Vessel	Air Lifter Vessel	Single Wall Dish Bottom Vessel with Heating Blanket	Single Wall Plain Bottom Vessel with Heating Base Unit	Solid State
Mammalian Cell Culture		●●	●○	○○	●○	○○	○○
Aerobic Microorganism Culture (Note 1)		●●	●●	●●	●●	●●	○○
Micro-aerobic Microorganism Culture (Note 2)		●●	●●	○○	●●	●●	○○
Anaerobic Microorganism Culture (Note 3)		●●	●●	○○	●●	●●	○○
Fragile Cell Culture (Note 4)		●●	●○	●●	●○	○○	○○
Photosynthesis Cell Culture (Note 5)		●○	●●	●●	○○	●○	○○
Plant Cell Culture		●○	●○	●●	○○	○○	○○
Insect Cell Culture		●●	●○	○○	●○	○○	○○
Solid State / Semi-solid State		○○	○○	○○	○○	○○	●●

●● Excellent      ●○ Good      ○○ Not recommended

Note:

1. Some bacteria; yeast; fungi

2. Facultative culture (For example, some Lactobacillus; ethanol production)

3. Same as Note 2

4. This vessel is excellent for fragile cells that are easily sheared by any type of mechanical impeller

5. Plant; algae; cyanobacteria (blue-green algae)

## Optional Devices and Accessories

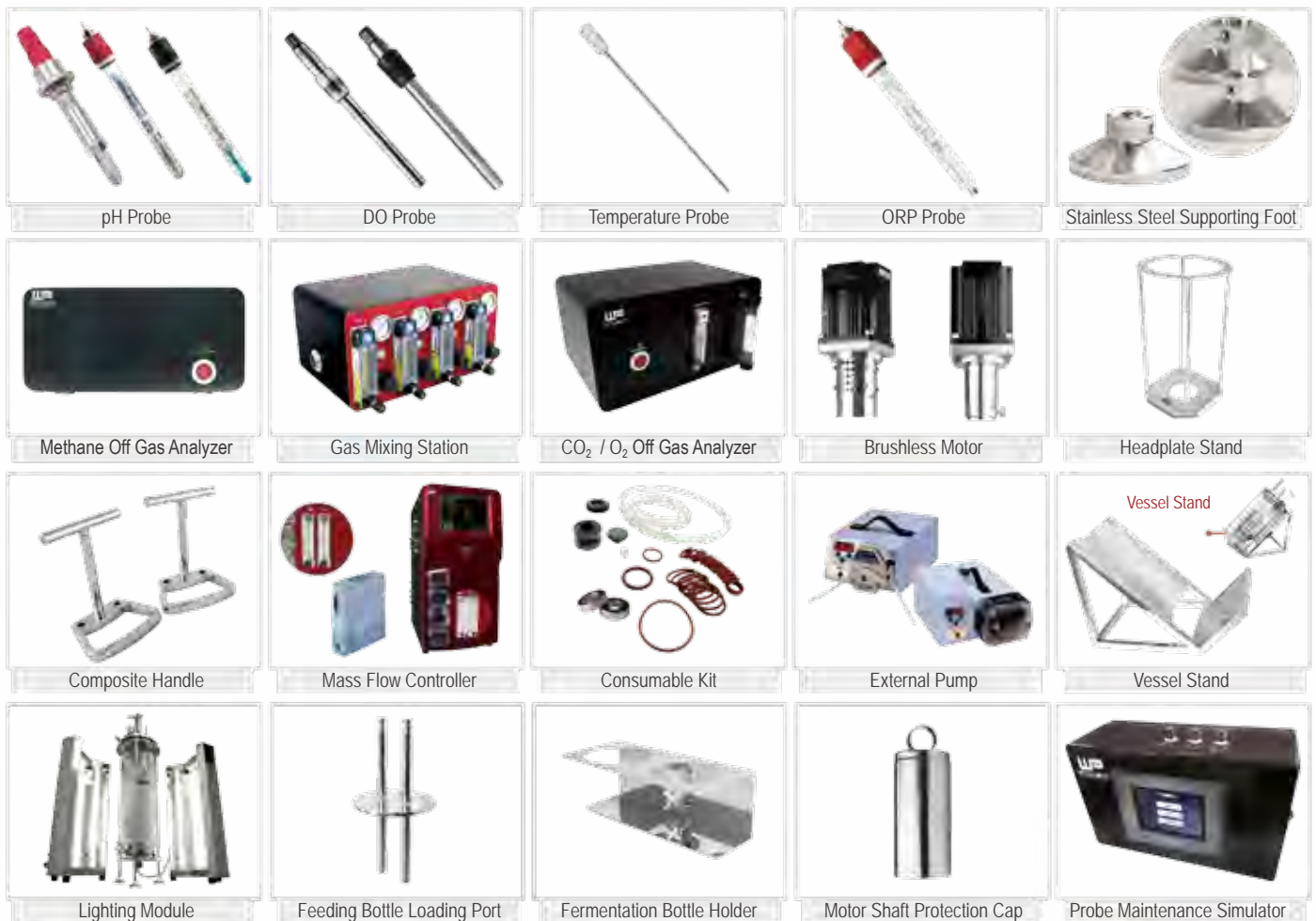

### Other Optional Devices:

- Antifoam Probe
- Impellers
  - Rushton 6 Blade Impeller
  - Pitched Blade Impeller
  - Foam Breaker Impeller
  - Broken Type Impeller (5L only)
  - Anchor Type Impeller (5L only)
  - Spiral Type Impeller (5L only)
- Sampling Devices
  - Triport Sampling Device
  - Dual Ports Sampling Device
  - Ball Valve Sampling Device
  - Pneumatic Sampling Device
- EZScript Software
- Optical Density Sensor Modules
- Quad Loading Port
- Stainless Steel Condenser
- Protective Double Jacket 5 Liter Vessel Cover In Sterilization



\*Please contact Major Science for more information on Other Optional Devices.



# SIP (Pilot Scale) Fermentation System / Bioreactor

The 10L / 30L / 50L SIP Pilot Scale Fermentation Systems allow you to run small volume of fermentation experiment with ease. These systems are perfectly suitable for small scaling up in the academic lab. The easy programming and operation on our Winpact software put your operation procedure in your peace of mind. System comes with rolling wheels for mobility. All materials are made from the highest standard to ensure optimization of your fermentation process. A variety of optional devices are also available for selection to maintain your optimum performance



FS-10L

## 10L / 30L / 50L System

**Harvest valve**  
sterilizable, diaphragm-type tank bottom valve for sanitary post-process harvest

**Sampling valve**  
steam-sterilizable valve permits repeatedly sanitary sample collection

**Motor**  
Manual or automatic control of constant agitation speed

**Control Station**  
Large screen and graphical user interface

**Peristaltic Pump**  
Uses four Watson Marlow built-in peristaltic pumps for all your feeding needs



FS-50L



FS-30L

**Stainless Steel Vessel**  
Special designed heating jacket provides better heating efficiency

\* ASME standard  
\* All images are for reference only, actual products might differ from the pictures above.



50L Bioreactor

**Features**

- Wide range of vessel selection, from 10L to 50L working volume
- Multi-lingual 10.4" and above colored graphical control interface
- Fully automated process with remote monitoring
- 15-step automatic program setting
- Orbital welding ensures minimal residue buildup
- Highest grade construction with 316L stainless steel
- Jacket design provides astounding temperature control
- Exhaust pressure relief valve for maximum safety precaution
- Multiple safety design integration for peace of mind operation
- Remote monitoring & controlling software free from purchase
- Password protection for multiple users with customized access levels
- Various optional devices for process optimization and needs
- Ethernet communication with Winpact SCADA software, and IP address

<b>Capacity</b>	10L	30L	50L
<b>Total Volume</b>	15L	42L	67L
<b>Working Volume</b>	10L	30L	50L
<b>Vessel And Jacket Maximum Working Pressure</b>	3 bar (43.5 psig) / 4 bar (58 psig)		
<b>Type</b>	Double layered fully enclosed capsule-type tank		
<b>Material</b>	Direct contact to medium - 316L stainless steel; all others - 304 stainless steel		
<b>Surface Finish</b>	Interior polish $\leq 5$ Ra/in (0.6 $\mu$ m) Mechanical polishing; Electropolish optional Exterior polish $\leq 32$ Ra/in (0.8 $\mu$ m) Mechanical polishing; Electropolish optional		

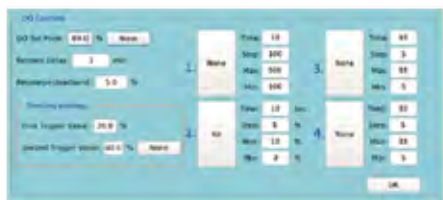

Four-staged DO cascade



15-Step programmable PID control

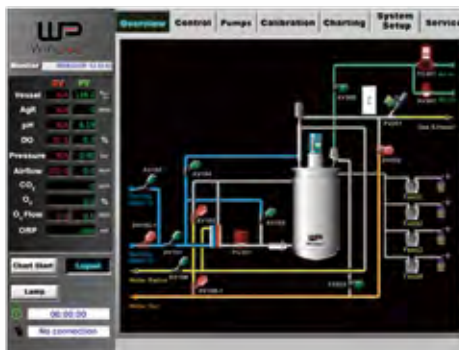

Immediate visualization on operation overview



Easy and intuitive operation for manual and sequence control



One-Touch automatic sterilization for vessel and system tubing



Online system calibration with system feedback



System expansion with various optional devices



# SIP (Production Scale) Fermentation System

Winpact offers pilot and production scale bioreactor/fermentation systems for all of your large scale fermentation needs. Our standard SIP Production Scale Fermentation System is constructed with BPE standard piping with orbital welding and top grade automatic valves to allow stable and repeatable result for every experiment. All of our features are designed to provide a high level of productivity and automation while maintaining a low operation cost. All other great features including total sterilization process, mechanical seal break indication, golden vessel ratio design and complete selection of optional devices for optimizing the fermentation process.

**Features**

- Wide range of vessel selection, from 100L to 1000L working volume
- Multi-lingual 12" colored graphical control interface
- Fully automated process with remote monitoring
- 15-step automatic program setting
- Orbital welding ensures minimal residue buildup
- Highest grade construction with Stainless Steel SUS316L
- Hive jacket design provides astounding temperature control
- Exhaust pressure relief valve for maximum safety precaution
- Multiple safety design integration for peace of mind operation
- Remote monitoring & controlling software free from purchase
- Password protection for multiple users with customized access levels
- Various optional devices for process optimization and needs
- Ethernet communication with Winpact SCADA software, and IP address



**200L**

Detachable aseptic feeding device

Harvest valve Sanitary level diaphragm type tank bottom valve

Pump



Mechanical seal with auto generated lubricant and automatic cooling device



- Pneumatic valves for accurate and automatic control



- Orbital welding provides top quality

\* Customized vessel is available



**100L**

**500L**

**1000L**

<b>Capacity</b>	100L	200L	500L	1000L
<b>Total Volume</b>	120L	268L	700L	1500L
<b>Working Volume</b>	100L	200L	500L	1000L
<b>Vessel And Jacket Maximum Working Pressure</b>	3 bar (43.5 psig) / 3 bar (43.5 psig)			
<b>Type</b>	Double layered fully enclosed capsule-type tank, with an outer temperature protective layer			
<b>Material</b>	Direct contact to medium - 316L stainless steel; all others - 304 stainless steel			
<b>Surface Finish</b>	Interior polish ≤5 Ra/in (0.6 μm) Mechanical polishing; Electropolish optional Exterior polish ≤32 Ra/in (0.8 μm) Mechanical polishing; Electropolish optional			

\* For bigger capability system. please contact Major Science and/or our distributor partners.

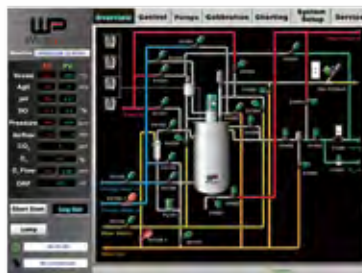

Monitor page for operation overview



Automatic and manual operation



Automatic sterilization process



Online system calibration



## Power Supply

The Major Science power supplies are perfect for your everyday use for electrophoresis. Our power supply is ideal for DNA, RNA and protein electrophoresis as well as blotting.

Major Science power supply are available for routine horizontal and vertical electrophoresis. These safe and user-friendly power supplies consist of advanced specification, high performance, long life span, and compact sizing.

## Electrophoresis System

Major Science offers a comprehensive line of equipment and related products for a variety of electrophoresis experiments. This portfolio includes full-sized horizontal and vertical cells, electro-blotting systems, semi-dry blotting systems and other products.

### Electrophoresis and Related Products

#### ▣ Power Supply

**19-23**

Handy 100V  
Mini Pro 300V / 500V  
Lively 300V / 500V / 3AP

#### ▣ Nucleic Acid Electrophoresis

**24-33**

Mini Horizontal  
Midi plus / plus-1 / plus-2 Horizontal  
Maxi Horizontal  
Midi96 plus-1 & Super plus gel

#### ▣ Protein Electrophoresis

**34-39**

Mini Vertical  
Mini Wide / Maxi Plus Vertical  
Maxi WAVE Vertical

#### ▣ Blotting

**40-42**

Complete Mini / Mini Wide / Maxi Electro Blot System  
Semi Dry Mini and Semi Dry Midi

#### ▣ Special Application

**43-47**

Comet Assay Tanks / Dot and Slot Blotters  
Clinical Electrophoresis Cellulose Acetate Electrophoresis  
Denaturing Gradient Electrophoresis  
Gradient Formers / Cool Cube / FlatBed IEF System  
Midi Gel Dryer

#### ▣ Pipette

**48-49**

MS Pipette



# Handy 100V Power Supply

## MP-100

The Handy 100V Power Supply is specifically designed for DNA and RNA electrophoresis. It allows for two constant voltages of either 50V or 100V. The low cost, light weight and small foot print make it perfect for teaching labs as well as routine electrophoresis use. It can be purchased individually or in packages with horizontal gel electrophoresis systems to be more economical.

### Features

- 50V or 100V constant voltage output
- 400mA maximum current
- 40W maximum power
- Safety device
- Ultra compact size and lightweight
- Developed specifically for DNA and RNA electrophoresis
- Great value at very competitive pricing
- Bundled package with MJ-105A and MT-108

### Specifications

Cat. No.	MP-100
Output Voltage	50V / 100V
Output Current	400mA
Output Power	40W
Output Type	Constant voltage
Voltage Selection	50V and 100V
Safety Device	No-load detection; shrouded plugs and sockets
Operation Temperature	4°C - 40°C
Dimension (WxLxH)	Approx. 2.4"x1.6"x4.7" (60x40x120mm)
Terminal Pairs	1 pair
Material	Polycarbonate (PC)
Weight	Approx. 0.7lb (0.3kg)
Rated Voltage	100 - 120V- only

### Ordering Information

Cat. No.	Product Description
MP-100	Handy 100V Power Supply

### Bundle Packages

Electrophoresis Package	Product Description
MJA-100P	Package of MJ-105A and MP-100
MT-100P	Package of MT-108 and MP-100
MJAE-100P	Package of MJ-105A, MP-100, and MBE-300; amber filter lid with fan, synthetic paper hood are included



MP-100



MJA-100P

MT-100P

MJAE-100P

Specifically designed for DNA and RNA electrophoresis.

\*All images are for reference only, actual products might differ from the images.

\*Please visit our website at [www.majorsci.com](http://www.majorsci.com) for more product selection and detailed information.

\*Technical specification subject to change without notice.



## Mini Pro 300V / 500V Power Supply

MINI-300  
MINI-500

Featuring in small size and versatility, the newly designed Mini Pro 300V / 500V Power Supply are ideal choices for any researchers. Capable of providing constant voltage or current in 1V or 1mA increment, the unit is perfectly suitable to run both vertical polyacrylamide or horizontal agarose gel electrophoresis experiments. Continuous or timed operation can be easily set up using the simple and user-friendly interface. Moreover, the upgraded 2 step programmable function is more practical for protein electrophoresis. Mini Pro 300V and 500V both feature 2 electrode pairs, allowing 2 gels to be run simultaneously, saving both time and valuable bench space. With an universal voltage rating, Mini Pro 300V and 500V are also designed and constructed to the most rigorous safety standards. Package including single or dual horizontal electrophoresis system and mini vertical electrophoresis system are excellent choices for educational or person lab purposes.

### Features

- Constant voltage or constant current operation
- 1V increment voltage control; 1mA increment current control
- Max 300V, 400mA and 60W for Mini Pro 300V
- Max 500V, 400mA and 120W for Mini Pro 500V
- Two pairs of outlet terminals
- Timer with alarm function
- Safety device
- Compact size and lightweight
- Competitive pricing choice
- Packages with midi sized horizontal electrophoresis systems and vertical electrophoresis systems
- 2 step programmable control



MINI-300



MINI-500



2 step programmable control

## Specifications

Cat. No.	MINI-300	MINI-500
Output Voltage / Inc.	Step1: 10 - 300V / 1V Step2: 10 - 300V / 1V	Step1: 10 - 500V / 1V Step2: 10 - 500V / 1V
Output Current / Inc.	Step1: 10 - 400mA / 1mA Step2: 10 - 400mA / 1mA	Step1: 1 - 400mA / 1mA Step2: 1 - 400mA / 1mA
Power	60W	120W
Output Type	Constant voltage or constant current	
Control	Microprocessor controller	
Terminal Pairs	2 pairs	
Timer	999 (min) with alarm / continuous (set=0)	
Safety Device	No load detection; shrouded plugs and sockets	
Operation Temperature	4°C - 40°C	
Dimension (WxLxH)	Approx. 5.5"x7.5"x3.3" (140x191x84mm)	
Material	Polycarbonate housing and aluminum base plates	
Weight	Approx. 2.2lb (1kg)	
Rated Voltage	100 - 240V~, 50-60Hz, 2A	100 - 240V~, 50-60Hz, 2.5A
Program	2-STEP Program	
Presetting Value	STEP1( V: 300V ); STEP2( V: 300V ) STEP1( A: 16mA ); STEP2( A: 24mA ) STEP1( T: 15min ); STEP2( T: 120min )	STEP1( V: 500V ); STEP2( V: 500V ) STEP1( A: 16mA ); STEP2( A: 24mA ) STEP1( T: 30min ); STEP2( T: 240min )
	*if time is set 0, system will keep running until user manually stops. *If voltage or current is set 0 in step 2, system will not proceed to step 2.	



MJA-Mini300



MT-Mini300



MJAE-Mini300



ME7-Mini300



ME10-Mini300



ME15-Mini300



MV10-Mini300

## Ordering Information

Cat. No.	Product Description
MINI-300	Mini Pro 300V Power Supply
MINI-500	Mini Pro 500V Power Supply

## Bundle Packages

Single Electrophoresis Packages	
MJA-Mini300	Package of MJ-105A and MINI-300
MT-Mini300	Package of MT-108 and MINI-300
MJAE-Mini300	Package of MJ-105A, MINI-300, and MBE-300; amber filter lid with fan, synthetic paper hood are included

Single Electrophoresis Packages	
ME7-Mini300	Package of ME 7-7-10 and MINI-300
ME10-Mini300	Package of ME10-7-10 and MINI-300
ME15-Mini300	Package of ME15-7-10-15 and MINI-300
MV10-Mini300	Package of MV-10DSYS and MINI-300
MINI500-CP-02	Package of MINI-500 and MV-30DSYS
MINI500-CP-03	Package of MINI-500 and MV-20WAVESYS

Dual Electrophoresis Packages	
MJAA-Mini300	Package of 2 x MJ-105A and MINI-300
MTT-Mini300	Package of 2 x MT-108 and MINI-300
MJAT-Mini300	Package of MJ-105A & MT-108 and MINI-300

## Dual Electrophoresis Packages



MINI500-CP-02



MINI500-CP-03



MJAA-Mini300



MTT-Mini300



MJAT-Mini300



## Lively 300V/ 500V/ 3AP Power Supply

MP-310  
MP-510  
MP-320

Major Science offers 3 models of power supplies constructed with microprocessor controller and 4 pairs of outlet terminals which covers the broadest range of application in general laboratory. The microprocessor control can perform either continuous or timed output, and user is able to pause and resume anytime without resetting the timer.

MS Lively Power Supply is power enough to perform horizontal and vertical electrophoresis as well as two dimensional electrophoresis SDS-PAGE applications. In addition, it can operate with a fully programmable mode and offer up to 6 multi-step setting conditions. The 2.4" TFT-LCD colored screen also allows you to see all the running/setting conditions while operating. For those beginners in electrophoresis, the built-in data for some typical running condition could be extremely helpful. All 3 models are designed with great safety features to ensure safety of the lab and experiment.



MP-310



MP-510



MP-320



### Features

- Four pairs of output terminals
- 2.4" TFT-LCD colored screen shows all parameters during operation
- Timer with alarm function
- Compact size with stackable case
- Constant voltage/ current/ power operation mode
- Typical running condition helps electrophoresis beginner
- Wide application for DNA, RNA and protein electrophoresis and blotting
- Advanced safety device design
- Universal rated voltage for worldwide distributions

## Specifications

Cat. No.	MP-310	MP-320	MP-510
Output Voltage / Inc.	5 - 300V / 1V	5 - 300 / 1V	5 - 500 / 1V
Output Current / Inc.	1 - 700mA / 1mA	10 - 3,000mA / 10mA	1 - 800mA / 10mA
Power	150W	300W	300W
Rated Voltage	100-240V~; 47-60Hz	100-240V~; 47-60Hz	100-240V~; 47-60Hz
Type Of Output	1. Voltage or Current with automatic crossover 2. When target constant mode is set, system automatically adjusts the two other parameter to maximum to allow constant run (later could be changed by user)		
Program Storage	30 programmed files		
Program Multi-Step	Up to 6 steps		
Editable Program Function	1. Typical running conditions program 2. Manual editable program		
Display	2.4" TFT		
Control	Microprocessor controller		
Safety Device	No Load detect		
	Leakage detect		
	Over temperature protection		
	Over load detection		
	Sudden load change detection (could be enabled by proper setting)		
Timer	Shrouded plugs and sockets		
	Constant: 9999 (min) with alarm / continuous Program: 999 (min) with alarm / continuous		
Crossover	YES		
Stackable	YES		
Automatic Recovery After Power Failure	YES		
Operating Temperature	4°C- 40°C		
Construction Material	PC housing and flame retardant ABS faceplate		
Dimension (WxLxH)	Approx. 8.5"x13.2"x4.1" (215x335x104mm)		
Weight	Approx. 4.6lb (2.1kg)		

## Ordering Information

Cat. No.	Product Description
MP-310	Lively 300V Power Supply
MP-320	Lively 3AP Power Supply
MP-510	Lively 500V Power Supply



Four pairs of outlet terminals



Stackable case



# Mini Horizontal Gel Electrophoresis System

## MJ-105A MT-108

For MJ-105A

The MJ-105A horizontal electrophoresis system offers many advantages for nucleic acid separation. Agarose gels are convenient to cast and samples are easy to load with this recognizable mini horizontal cell. Its molded design prevents cracks and leakages and the sturdy PC provides a 130°C temperature capacity. The safety interlock cover is designed to prevent electrical hazards during electrophoresis. It is ideal for several applications, including Northern and Southern blotting, Cosmid library restriction analysis, STS screening, microsatellite analysis, PCR fragment analysis, RFLP analysis, DNA finger-printing and high throughput analysis.

For MT-108

MT-108 horizontal electrophoresis units offer many advantages for nucleic acid separation. Agarose gels are easy to cast and samples are easy to load. MT-108's longer tray allows running of bigger fragments to attain higher resolution. Its molded design prevents cracks or leakages, and its sturdy PC provides a temperature capacity of up to 130°C. A safety interlocking cover is designed to prevent electrical hazards during electrophoresis runs. It is ideal for many applications, including Northern and Southern blotting, Cosmid library restriction analysis, STS screening, Microsatellite analysis, PCR fragment analysis, RFLP analysis, DNA fingerprinting and high-throughput analysis.

### Features

- Less agarose consumption
- Less running buffer consumption
- Multichannel pipette-compatible
- Single molded tank
- Safety & Ventilation lid
- High temperature capability, 130°C
- Easy sample loading
- Great indications for gel making and running
- No tapes, clamps or springs needed for gel casting
- No direct heat impact from power supply unit

### For MJ-105A additional features

- Transparent tank and lid
- Real time observation with MBE-300
- Contains 2 sets of gel maker stand
- Cast 6 pcs of agarose gel in one time

### For MT-108 additional features

- Two tray options available
- Cast 3 pcs of agarose gel in one time



MJ-105A

MJ-105A is offered as a complete system for the user to cast, and run electrophoresis. including:

- 1 x Transparent tank and transparent lid
- 2 x MJ-G01 (Gel Maker Stand)
- 2 x MJ-T02 (107x60mm Tray)
- 4 x MJ-T01 (52x60mm Tray)
- 1 x MJ-C01 (Double side comb: 8 teeth x 2 & 17 teeth; 12 teeth x 2 & 25 teeth)
- 1 x MT-C03 (Multiple pipette compatible 23 teeth, Prep 1 & Marker 2, Prep 2 & Marker 2; 6 teeth x 2 for mini gel & 12 teeth for midi gel)
- 1 x Black & red electrophoresis cable



Multichannel pipette compatible

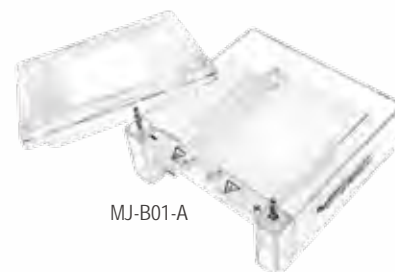

MJ-B01-A



MT-108

MT-108 is offered as a complete system for the user to cast, and run electrophoresis. including:

- 1 x Snow tank and transparent lid
- 1 x MT-G01 (Gel Maker Stand)
- 1 x MT-T01 (105x83mm Tray)
- 2 x MT-T02 (50x83mm Tray)
- 1 x MJ-C01 (Double side comb: 8 teeth x 2 & 17 teeth; 12 teeth x 2 & 25 teeth)
- 1 x MT-C03 (Multiple pipette compatible 23 teeth, Prep 1 & Marker 2, Prep 2 & Marker 2; 6 teeth x 2 for mini gel & 12 teeth for midi gel)
- 1 x Black & red electrophoresis cable

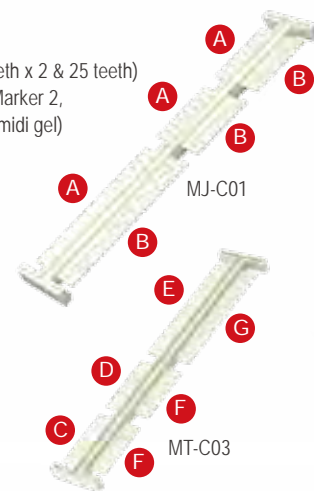
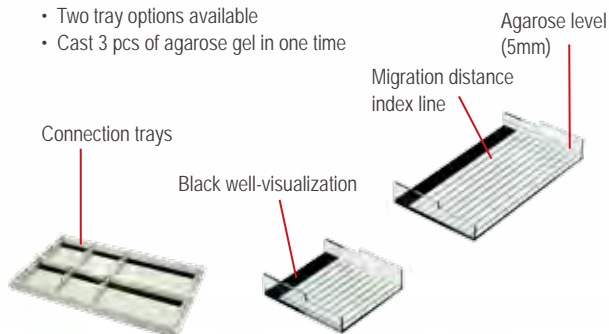

	Cat. No.	Tooth Thickness	Tooth Width	Sample Volume for a 5mm thick gel (ul)
A	MJ-C01	1.0mm	4.0mm	20
B	MJ-C01	1.5mm	2.8mm	21
C	MT-C03	1.0mm	36.0mm	180
D	MT-C03	1.0mm	17.0mm	85
E	MT-C03	1.0mm	3.0mm	15
F	MT-C03	1.0mm	6.0mm	30
G	MT-C03	1.0mm	6.5mm	32.5

## Specification

Cat. No	MJ-105A	MT-108
Appearance	Transparent tank & transparent lid	Snow tank & transparent lid
Material	PC (Polycarbonate)	
Lid Material	PC (Polycarbonate)	AS (Acrylonitrile-Styrene Copolymer)
Temperature Capacity	130°C	
Transparent Lid	Safety ventilation design	
Gel Dimension (WxL)	4.2"x2.4" (107x60mm)	4.1"x3.3" (105x83mm)
	2.1"x2.4" (52x60mm)	2"x3.3" (50x83mm)
Tray	Black well-visualization strip Migration distance index line Agarose level, 0.2" (5mm)	
Rapid Casting Gel	Use gel maker stand	
Maximum Gel Thickness	0.39" (10mm)	
Maximum Sample	25 samples	
Buffer Volume	0.05gal (200ml)	0.11gal (400ml)
Operating Temperature	4 - 40°C	
Dimension (WxLxH)	5.8"x5.7"x2.3" (148.3x145.8x59.1mm)	5.4"x7.4"x2.3" (136x188x58mm)
Weight	Approx. 1.1lb (0.5kg)	Approx. 1.5lb (0.7kg)

## Accessories

Cat. No	Product Description
<b>MJ-105A Accessories</b>	
MJ-B01-A	Transparent tank and lid, without accessories
MJ-LID-AM580	580nm amber filter lid with fan, suitable for MJ-105A
MBE-LID-AM580	An inclined 580nm amber filter, suitable for MBE-200 and MBE-300
MJ-G01	Gel maker stand
MJ-T01	52x60mm Tray
MJ-T02	107x60mm Tray
MJ-C01	Analytical comb (8 teeth x 2 for mini gel & 17 teeth for midi gel (thickness: 1.0mm), 12 teeth x 2 for mini gel & 25 teeth for midi gel (thickness: 1.5mm))
MT-C03	Analytical comb 1.0mm-thick (multiple pipette compatible 23 teeth, Prep 1 & Maker 2, Prep 2 & Maker 2 on one side; 6 teeth x 2 for mini gel & 12 teeth for midi gel on the other side)
MBE-150-CABLE	Threaded Black and Red Electrophoresis Cable
MJ-CASTER-C	2 x MJ-G01; 4 x MJ-T01; 2 x MJ-T02; 1 x MJ-C01 and 1 x MT-C03
MBE-HOOD	Synthetic paper hood
<b>MT-108 Accessories</b>	
MT-B01	Wide Mini Tank and lid, without accessories
MT-G01	Gel maker stand
MT-T01	105x83mm Tray
MT-T02	50x83mm Tray
MJ-C01	Analytical Comb (8 teeth x 2 for mini gel & 17 teeth for midi gel (thick: 1.0mm), 12 teeth x 2 for midi gel & 25 teeth for midi gel (thick: 1.5mm))
MT-C03	Analytical Comb 1.0mm-thick (multiple pipette compatible 23 teeth, Prep 1 & Maker 2, Prep 2 & Maker 2 on one side; 6 teeth x 2 for mini gel & 12 teeth for midi gel on the other side)
MT-P01	Electrophoresis Cable (black and red) for MT-108 only
MT-CASTER-C	1 x MT-G01; 1 x MT-T01; 2 x MT-T02; 1 x MJ-C01 and 1 x MT-C03



## Ordering Information

Cat. No	Product Description
MJ-105A	Transparent Mini Horizontal Electrophoresis System
MT-108	Wide Mini Horizontal Electrophoresis System
<b>Single Electrophoresis Packages</b>	
MJA-100P	Package of MJ-105A and MP-100
MT-100P	Package of MT-108 and MP-100
MJA-Mini300	Package of MJ-105A and MINI-300
MJAE-100P	Package of MJ-105A, MP-100, and MBE-300; amber filter lid with fan, synthetic paper hood are included
MJAE-Mini300	Package of MJ-105A, MINI-300, and MBE-300; amber filter lid with fan, synthetic paper hood are included
MJA-MBEP	Package of MJ-105A and MBE-300; amber filter lid with fan, synthetic paper hood are included
MT-Mini300	Package of MT-108 and MINI-300
<b>Dual Electrophoresis Packages</b>	
MJAA-Mini300	Package of 2 x MJ-105A and MINI-300
MTT-Mini300	Package of 2 x MT-108 and MINI-300
MJAT-Mini300	Package of MJ-105A & MT-108 and MINI-300

## Single Electrophoresis Packages



## Dual Electrophoresis Packages





## Midi plus / plus-1 / plus-2 Horizontal Electrophoresis System

ME7-7-10  
ME10-7-10  
ME15-7-10-15

Our Midi series have been designed for routine horizontal gel electrophoresis with wide degrees of versatility. All of our gel tanks are made from injection molded construction for durable and leak proof environment. Varieties of special combs are available to maximize your sample size.

Midi plus includes the 70x70 and 70x100mm gel trays for a maximum of 64 samples, designed for low to medium numbers of samples.

Midi plus-1 includes 100x70 and 100x100mm gel tray to allow 100 samples per gel to be resolved. Ideal for those routinely check medium numbers of samples over short to medium gel run lengths.

The Midi plus-2 system provides three sizes of trays to maximize your sample size, 150x70, 150x100, 150x150mm. Midi plus-2 allows up to 210 samples per run per gel.

Easy click lid removal

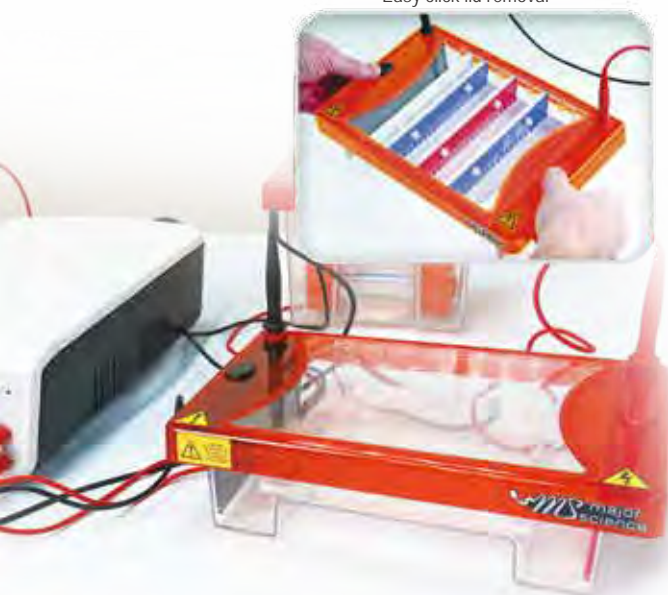

### Features

- Low buffer consumption
- Single molded tank
- Two tray options available (ME7-7-10, ME10-7-10)
- Three tray options available (ME15-7-10-15)
- Easy sample loading
- Multi-channel pipette compatibility
- Great indications for gel making and running
- No tape, clamps or springs needed

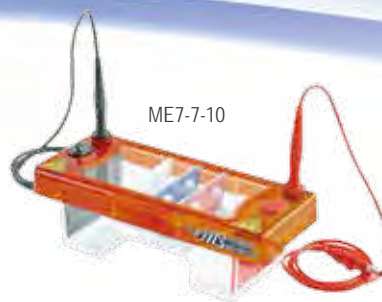

ME7-7-10

CE

ME7-7-10 is offered as a complete system for the user to cast, and run electrophoresis. including:

- 1 x Electrophoresis tank & lid
- 1 x ME7-UV7 (70x70mm UV tray)
- 1 x ME7-UV10 (70x100mm UV tray)
- 2 x ME7-8-1 (8 sample combs, 1mm thick)
- 1 x ME7-UVDAM (UV tray dams, 2pcs)
- 1 x ME7-LG (Loading guides (Set))
- 1 x Black & red electrophoresis cable



ME10-7-10

CE

ME10-7-10 is offered as a complete system for the user to cast, and run electrophoresis. including:

- 1 x Electrophoresis tank & lid
- 1 x ME10-UV7 (100x70mm UV tray)
- 1 x ME10-UV10 (100x100mm UV tray)
- 2 x ME10-16-1 (16 sample combs, 1mm thick)
- 1 x ME10-UVDAM (UV tray dams, 2pcs)
- 1 x ME10-LG (Loading guides (Set))
- 1 x Black & red electrophoresis cable

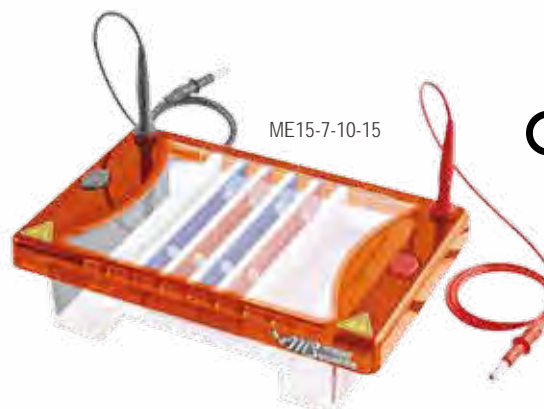

ME15-7-10-15

CE

ME15-7-10-15 is offered as a complete system for the user to cast, and run electrophoresis. including:

- 1 x Electrophoresis tank & lid
- 1 x ME15-UV7 (150x70mm UV tray)
- 1 x ME15-UV10 (150x100mm UV tray)
- 1 x ME15-UV15 (150x150mm UV tray)
- 2 x ME15-20-1 (20 sample combs, 1mm thick)
- 1 x ME15-UVDAM (UV tray dams, 2pcs)
- 1 x ME15-LG (Loading guides (Set))
- 1 x Black & red electrophoresis cable

## Specification

Cat. No.	ME7-7-10	ME10-7-10	ME15-7-10-15
Dimension (WxLxH)	8.3"x3.5"x3.5" (210x90x90mm)	8.7"x4.9"x3.5" (220x125x90mm)	10.4"x6.9"x3.5" (265x175x90mm)
Gel Dimension (WxL)	2.8"x2.8" (70x70mm) 2.8"x3.9" (70x100mm)	3.9"x2.8" (100x70mm) 3.9"x3.9" (100x100mm)	5.9"x2.8" (150x70mm) 5.9"x3.9" (150x100mm) 5.9"x5.9" (150x150mm)
Maximum Sample	32 for 2.8"x2.8" (70x70mm) Tray (2x16 sample combs)	50 for 3.9"x2.8" (100x70mm) Tray (2x25 sample combs)	70 for 5.9"x2.8" (150x70mm) Tray (2x35 sample combs)
	64 for 2.8"x3.9" (70x100mm)Tray (4x16 sample combs)	100 for 3.9"x3.9" (100x100mm) Tray (4x25 sample combs)	140 for 5.9"x3.9" (150x100mm) Tray (4x35 sample combs)
			210 for 5.9"x5.9" (150x150mm) Tray (6x35 sample combs)
Buffer Volume	0.06gal (225ml)	0.08gal (300ml)	0.13gal (500ml)
Construction	Injection molded construction		
	Durable, leak proof environment for complete safety and long life		
Cassette Type Electrode	Inexpensive, easy to replace		
	Made of 99.99% corrosion resistant pure platinum		
Electrical Safety	Lid can only be fastened in one way		
	Upon lid removal, power is disconnected from buffer chamber		
Rapid Casting Gel	Use casting dams		

## Ordering Information

Cat. No.	Product Description
ME7-7-10	Midi plus, 70x70mm & 70x100mm UV tray, 2x8 sample 1mm thick combs, loading guides and dams
ME7-Mini300	Package of ME7-7-10 and Mini-300
ME7-UV7	Midi plus, 70x70mm UV tray
ME7-UV10	Midi plus, 70x100mm UV tray
ME7-UVS	70mm UV gel scoop
ME7-UVDAM	Midi plus, UV tray dams ( 2 pcs )
ME7-LG	Loading Guides
ME7LID	Midi plus lid (No cables)
ME7TANK	Midi plus Tank (including electrodes)
ME7-BSB	Buffer Saver Blocks for Midi plus, package of 2
ME10-7-10	Midi plus-1, 100x70mm & 100x100mm UV tray, 2x16 sample 1mm thick combs, loading guides and dams
ME10-Mini300	Package of ME10-7-10 and Mini-300
ME10-UV7	Midi plus-1, 100x70mm UV tray
ME10-UV10	Midi plus-1, 100x100mm UV tray
ME10-UVS	100mm UV gel scoop
ME10-UVDAM	Midi plus-1, UV tray dams ( 2 pcs )
ME10-LG	Loading Guides for Midi Plus-1
ME10LID	Midi plus-1 lid (No cables)
ME10TANK	Midi plus-1 Tank (including electrodes)
ME10-BSB	Midi plus-1 buffer saving block, save up to 100ml, 2/pk
ME7/10-FC	Midi plus/Midi plus-1, Flexicaster
ME15-7-10-15	Midi plus-2, 150x70, 100 & 150mm UV tray, 2x20 sample 1mm thick combs, loading guides and dams
ME15-Mini300	Package of ME15-7-10-15 and Mini-300
ME15-UV7	Midi plus-2, 150x70mm UV tray
ME15-UV10	Midi plus-2, 150x100mm UV tray
ME15-UV15	Midi plus-2, 150x150mm UV tray
ME15/20-FC	Midi plus-2/Maxi, Flexicaster
ME15-UVS	150mm UV gel scoop
ME15-UVDAM	Midi plus-2, UV tray dams ( 2 pcs )
ME15-LG	Loading Guides for Midi plus-2
ME15LID	Midi plus-2, lid (No cables)
ME15TANK	Midi plus-2 Tank (including electrodes)
ME15-BSB	Midi plus-2, saver blocks, pk/2





Casting dams allow gels to be rapidly cast

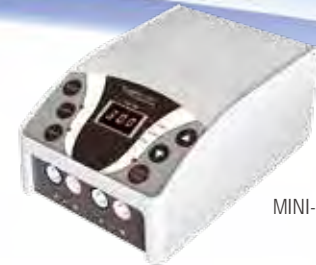

MINI-300

Recommended economic power supply

**For ME7-7-10**

Cat. No.	Comb Description	Sample Volume
ME7-1-0.75	Prep 1, Marker 1, 0.75mm thick	152ul
ME7-2-0.75	Prep 2, Marker 2, 0.75mm thick	68ul
ME7-4-0.75	Prep 4, Marker 2, 0.75mm thick	36ul
ME7-8MC-0.75	8 sample MC, 0.75mm thick	8ul
ME7-8-0.75	8 sample, 0.75mm thick	19ul
ME7-10-0.75	10 sample, 0.75mm thick	14ul
ME7-12MC-0.75	12 sample MC, 0.75mm thick	10ul
ME7-16-0.75	16 sample, 0.75mm thick	7ul

Cat. No.	Comb Description	Sample Volume
ME7-1-1.5	Prep 1, Marker 1, 1.5mm thick	304ul
ME7-2-1.5	Prep 2, Marker 2, 1.5mm thick	135ul
ME7-4-1.5	Prep 4, Marker 2, 1.5mm thick	72ul
ME7-8MC-1.5	8 sample MC, 1.5mm thick	17ul
ME7-8-1.5	8 sample, 1.5mm thick	37ul
ME7-10-1.5	10 sample, 1.5mm thick	27ul
ME7-12MC-1.5	12 sample MC, 1.5mm thick	20ul
ME7-16-1.5	16 sample, 1.5mm thick	15ul

ME7-1-1	Prep 1, Marker 1, 1mm thick	203ul
ME7-2-1	Prep 2, Marker 2, 1mm thick	90ul
ME7-4-1	Prep 4, Marker 2, 1mm thick	48ul
ME7-8MC-1	8 sample MC, 1mm thick	11ul
ME7-8-1	8 sample, 1mm thick	25ul
ME7-10-1	10 sample, 1mm thick	18ul
ME7-12MC-1	12 sample MC, 1mm thick	14ul
ME7-16-1	16 sample, 1mm thick	10ul

ME7-1-2	Prep 1, Marker 1, 2mm thick	405ul
ME7-2-2	Prep 2, Marker 2, 2mm thick	180ul
ME7-4-2	Prep 4, Marker 2, 2mm thick	96ul
ME7-8MC-2	8 sample MC, 2mm thick	23ul
ME7-8-2	8 sample, 2mm thick	50ul
ME7-10-2	10 sample, 2mm thick	36ul
ME7-12MC-2	12 sample MC, 2mm thick	27ul
ME7-16-2	16 sample, 2mm thick	20ul



Fast fix slot electrodes, no need rewiring



Complete package offers as standard

**For ME10-7-10**

Cat. No.	Comb Description	Sample Volume
ME10-1-0.75	Prep 1, Marker 1, 0.75mm thick	270ul
ME10-2-0.75	Prep 2, Marker 2, 0.75mm thick	118ul
ME10-4-0.75	Prep 4, Marker 2, 0.75mm thick	57ul
ME10-8-0.75	8 sample, 0.75mm thick	30ul
ME10-10MC-0.75	10 sample MC, 0.75mm thick	20ul
ME10-12-0.75	12 sample, 0.75mm thick	17ul
ME10-16-0.75	16 sample, 0.75mm thick	12ul
ME10-20MC-0.75	20 sample MC, 0.75mm thick	10ul
ME10-25-0.75	25 sample, 0.75mm thick	7ul

Cat. No.	Comb Description	Sample Volume
ME10-1-1.5	Prep 1, Marker 1, 1.5mm thick	540ul
ME10-2-1.5	Prep 2, Marker 2, 1.5mm thick	236ul
ME10-4-1.5	Prep 4, Marker 2, 1.5mm thick	115ul
ME10-8-1.5	8 sample, 1.5mm thick	61ul
ME10-10MC-1.5	10 sample MC, 1.5mm thick	41ul
ME10-12-1.5	12 sample, 1.5mm thick	34ul
ME10-16-1.5	16 sample, 1.5mm thick	24ul
ME10-20MC-1.5	20 sample MC, 1.5mm thick	20ul
ME10-25-1.5	25 sample, 1.5mm thick	15ul

ME10-1-1	Prep 1, Marker 1, 1mm thick	360ul
ME10-2-1	Prep 2, Marker 2, 1mm thick	158ul
ME10-4-1	Prep 4, Marker 2, 1mm thick	77ul
ME10-8-1	8 sample, 1mm thick	41ul
ME10-10MC-1	10 sample MC, 1mm thick	27ul
ME10-12-1	12 sample, 1mm thick	23ul
ME10-16-1	16 sample, 1mm thick	16ul
ME10-20MC-1	20 sample MC, 1mm thick	14ul
ME10-25-1	25 sample, 1mm thick	10ul

ME10-1-2	Prep 1, Marker 1, 2mm thick	720ul
ME10-2-2	Prep 2, Marker 2, 2mm thick	315ul
ME10-4-2	Prep 4, Marker 2, 2mm thick	153ul
ME10-8-2	8 sample, 2mm thick	81ul
ME10-10MC-2	10 sample MC, 2mm thick	54ul
ME10-12-2	12 sample, 2mm thick	45ul
ME10-16-2	16 sample, 2mm thick	32ul
ME10-20MC-2	20 sample MC, 2mm thick	27ul
ME10-25-2	25 sample, 2mm thick	20ul

\*Sample volume (SV) = Sample volume for 5mm thick gel (ul)

For ME15-7-10-15

Cat. No.	Comb Description	Sample Volume
ME15-1-0.75	Prep 1, Marker 1, 0.75mm thick	371ul
ME15-2-0.75	Prep 2, Marker 2, 0.75mm thick	169ul
ME15-4-0.75	Prep 4, Marker 2, 0.75mm thick	91ul
ME15-10-0.75	10 sample, 0.75mm thick	34ul
ME15-12-0.75	12 sample, 0.75mm thick	30ul
ME15-20-0.75	20 sample, 0.75mm thick	16ul
ME15-35-0.75	35 sample, 0.75mm thick	7ul
ME15-10MC-0.75	10 sample MC, 0.75mm thick	22ul
ME15-14MC-0.75	14 sample MC, 0.75mm thick	22ul
ME15-16MC-0.75	16 sample MC, 0.75mm thick	20ul
ME15-18MC-0.75	18 sample MC, 0.75mm thick	8ul
ME15-28MC-0.75	28 sample MC, 0.75mm thick	8ul
ME15-30MC-0.75	30 sample MC, 0.75mm thick	9ul

ME15-1-1	Prep 1, Marker 1, 1mm thick	495ul
ME15-2-1	Prep 2, Marker 2, 1mm thick	225ul
ME15-4-1	Prep 4, Marker 2, 1mm thick	122ul
ME15-10-1	10 sample, 1mm thick	45ul
ME15-12-1	12 sample, 1mm thick	41ul
ME15-20-1	20 sample, 1mm thick	21ul
ME15-35-1	35 sample, 1mm thick	10ul
ME15-10MC-1	10 sample MC, 1mm thick	29ul
ME15-14MC-1	14 sample MC, 1mm thick	29ul
ME15-16MC-1	16 sample MC, 1mm thick	27ul
ME15-18MC-1	18 sample MC, 1mm thick	11ul
ME15-28MC-1	28 sample MC, 1mm thick	11ul
ME15-30MC-1	30 sample MC, 1mm thick	13ul

Cat. No.	Comb Description	Sample Volume
ME15-1-1.5	Prep 1, Marker 1, 1.5mm thick	743ul
ME15-2-1.5	Prep 2, Marker 2, 1.5mm thick	338ul
ME15-4-1.5	Prep 4, Marker 2, 1.5mm thick	182ul
ME15-10-1.5	10 sample, 1.5mm thick	68ul
ME15-12-1.5	12 sample, 1.5mm thick	61ul
ME15-20-1.5	20 sample, 1.5mm thick	32ul
ME15-35-1.5	35 sample, 1.5mm thick	15ul
ME15-10MC-1.5	10 sample MC, 1.5mm thick	44ul
ME15-14MC-1.5	14 sample MC, 1.5mm thick	44ul
ME15-16MC-1.5	16 sample MC, 1.5mm thick	41ul
ME15-18MC-1.5	18 sample MC, 1.5mm thick	17ul
ME15-28MC-1.5	28 sample MC, 1.5mm thick	17ul
ME15-30MC-1.5	30 sample MC, 1.5mm thick	19ul

ME15-1-2	Prep 1, Marker 1, 2mm thick	990ul
ME15-2-2	Prep 2, Marker 2, 2mm thick	450ul
ME15-4-2	Prep 4, Marker 2, 2mm thick	243ul
ME15-10-2	10 sample, 2mm thick	90ul
ME15-12-2	12 sample, 2mm thick	81ul
ME15-20-2	20 sample, 2mm thick	43ul
ME15-35-2	35 sample, 2mm thick	20ul
ME15-10MC-2	10 sample MC, 2mm thick	59ul
ME15-14MC-2	14 sample MC, 2mm thick	59ul
ME15-16MC-2	16 sample MC, 2mm thick	54ul
ME15-18MC-2	18 sample MC, 2mm thick	23ul
ME15-28MC-2	28 sample MC, 2mm thick	23ul
ME15-30MC-2	30 sample MC, 2mm thick	25ul



Extensive range of combs  
 Black: 0.75mm for ultra resolved bands  
 White: 1mm supplied as standard  
 Red: 1.5mm for large sample volume  
 Blue: 2mm for large sample volume

\*Sample volume (SV) = Sample volume for 5mm thick gel (ul)



MC = Multi-channel pipette compatible

# Maxi Horizontal Gel Electrophoresis System

## ME20 series ME26-16-24-32

### For ME20 series

Maxi is primarily designed for resolution of high numbers of samples as in cloning or PCR experiments. Maxi allows ultra high-resolution separations over extended runs. Tray sizes correspond to standard blotter sizes. It also allows for easy sample transfer onto a membrane for further analysis. Three tray sizes are available, 200x200mm, 200x250mm and 200x100mm. Multi-channel pipette compatible combs for up to 40 samples each facilitate speed loading of up to 440 samples per gel. 50 sample combs (not multi-channel pipette compatible) allow maximum sample capability of 550 samples per gel.

### For ME26-16-24-32

Maxi-plus is designed for rapid screening of very large numbers of cloning or PCR samples, and it has the maximum capacity of 672 samples per gel. This allows loading and analysis of exactly seven 96 well format micro titer plates. The large gel run length of 320mm also allows resolution of samples over a long distance for separation of complex sample bands such as in restriction fragment analysis. Maxi-plus is available with a full length tray of 260x320mm or with two other tray length options of 260x160mm and 260x240mm so that user's exact requirements can be matched. In addition to options for single length gel trays, Maxi-plus is available with all three gel tray lengths to provide the maximum flexibility, versatility and value. Buffer recirculation ports are included as standard to allow enhanced resolution over extended runs, while loading guides enhance well visibility for easy sample loading.

### Features

- Low buffer consumption
- Multi-channel pipette compatibility
- Great indications for gel making and running
- No tape, clamps or springs needed

### For ME20 series additional features

- Up to 450 samples per tray

### For ME26-16-24-32 additional features

- Up to 672 samples per tray
- Three tray options available

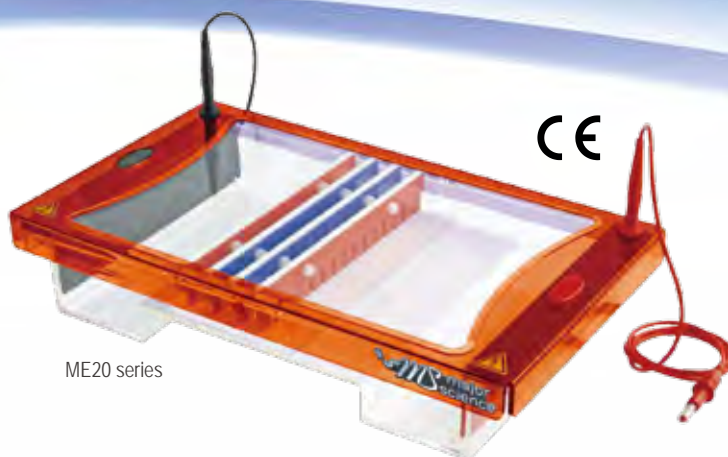

ME20 series

ME20 series is offered as a complete system for the user to cast, and run electrophoresis. including:

- 1 x Electrophoresis tank & lid
- 1 x ME20-UV10 (200x100mm UV tray)
- 1 x ME20-UV20 (200x200mm UV tray)
- 1 x ME20-UV25 (200x250mm UV tray, for ME20-25 only)
- 2 x ME20-20MC-1 (20 sample combs, 1mm thick)
- 1 x ME20-UV DAM (UV tray dams, 2pcs)
- 1 x ME20-LG (Loading guides (Set))
- 1 x Black & red electrophoresis cable

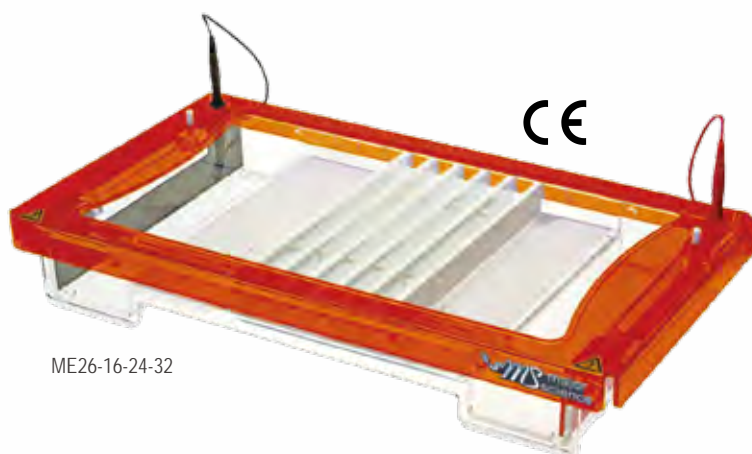

ME26-16-24-32

ME26-16-24-32 is offered as a complete system for the user to cast, and run electrophoresis. including:

- 1 x Electrophoresis tank & lid
- 1 x ME26-UV16 (260x160mm UV tray)
- 1 x ME26-UV24 (260x240mm UV tray)
- 1 x ME26-UV32 (260x320mm UV tray)
- 6 x ME26-28MC-1 (28 sample combs, 1mm thick)
- 1 x ME26-LG (Loading guides (Set))
- 1 x Black & red electrophoresis cable
- 1 x Flexi caster



All combs are multichannel pipette compatible



Loading guides allow easy well identification and sample loading



## Specification

Cat. No.	ME20-10-20	ME20-25	ME26-16-24-32
Dimension (WxLxH)	15.6"x9.1"x3.5" (395x230x90mm)		19.7"x11"x3.5" (500x280x90mm)
Gel Dimension (WxL)	7.9"x3.9" (200x100mm) 7.9"x7.9" (200x200mm) 7.9"x9.8" (200x250mm)(Optional)	7.9"x9.8" (200x250mm)	10.2"x6.3" (260x160mm) 10.2"x9.5" (260x240mm) 10.2"x12.6" (260x320mm)
Maximum Sample	200 for 7.9"x3.9" (200x100mm) Tray (4x50 sample combs) 450 for 7.9"x7.9" (200x200mm) Tray (9x50 sample combs)	550 for 7.9"x9.8" (200x250mm) Tray (11x50 sample combs)	336 for 10.2"x6.3" (260x160mm) Tray (6x56 sample combs) 504 for 10.2"x9.5" (260x240mm) Tray (9x56 sample combs) 672 for 10.2"x12.6" (260x320mm) Tray (12x56 sample combs)
Buffer Volume	0.32gal (1200ml)		0.37gal (1400ml)
Construction	Injection molded construction		N /A
	Durable, leak proof environment for complete safety and long life		N /A
Cassette Type Electrode	Inexpensive, easy to replace		
	Made of 99.99% corrosion resistant pure platinum		
Electrical Safety	Lid can only be fastened in one way		
	Upon lid removal, power is disconnected from buffer chamber		
Rapid Casting Gel	Use casting dams		Use flexible caster

## Ordering Information

Cat. No.	Product Description	Cat. No.	Product Description
ME20-10-20	Maxi, 200x100 & 200x200mm UV tray, 2x20 sample combs	ME26-16-24-32	Maxi-plus 260x160mm, 260x240mm, 260x320mm UV tray, 6x28 sample combs
ME20-25	Maxi, 200x250mm UV tray, 2x20 sample combs	ME26-UV16	Maxi plus, 260x160mm UV tray
ME20-UV10	Maxi, 200x100mm UV tray	ME26-UV24	Maxi plus, 260x240mm UV tray
ME20-UV20	Maxi, 200x200mm UV tray	ME26-UV32	Maxi plus, 260x320mm UV tray
ME20-UV25	Maxi, 200x250mm UV tray	ME26-FC	Flexible caster for gels up to 320mm. Casts 70, 100, 150,160, 200, 240 and 320mm long gels
ME15/20-FC	Midi plus-2/Maxi, Flexicaster	ME26-UVS	260mm UV gel scoop
ME20-UVS	200mm UV gel scoop	ME26-LG	Loading Guides for Maxi-plus
ME20-UVDAM	Maxi, UV tray dams ( 2 pcs )	ME26LID	Maxi-plus lid (No cables)
ME20-LG	Loading Guides for Maxi	ME26TANK	Maxi-plus Tank (including electrodes)
ME20LID	Maxi lid (No cables)		
ME20TANK	Maxi Tank (including electrodes)		

## Accessories

Cat. No	Comb Description	Sample Volume	Cat. No	Comb Description	Sample Volume
ME20-1-0.75	Prep 1, Marker 1, 0.75mm thick	506ul	ME20-16-1.5	16 sample, 1.5mm thick	61ul
ME20-2-0.75	Prep 2, Marker 2, 0.75mm thick	236ul	ME20-20MC-1.5	20 sample MC, 1.5mm thick	41ul
ME20-4-0.75	Prep 4, Marker 2, 0.75mm thick	115ul	ME20-25-1.5	25 sample, 1.5mm thick	32ul
ME20-10-0.75	10 sample, 0.75mm thick	54ul	ME20-30-1.5	30 sample, 1.5mm thick	26ul
ME20-16-0.75	16 sample, 0.75mm thick	30ul	ME20-36-1.5	36 sample, 1.5mm thick	22ul
ME20-20MC-0.75	20 sample MC, 0.75mm thick	20ul	ME20-40MC-1.5	40 sample MC, 1.5mm thick	17ul
ME20-25-0.75	25 sample, 0.75mm thick	16ul	ME20-50-1.5	50 sample, 1.5mm thick	16ul
ME20-30-0.75	30 sample, 0.75mm thick	13ul			
ME20-36-0.75	36 sample, 0.75mm thick	11ul	ME20-1-2	Prep 1, Marker 1, 2mm thick	1350ul
ME20-40MC-0.75	40 sample MC, 0.75mm thick	8ul	ME20-2-2	Prep 2, Marker 2, 2mm thick	630ul
ME20-50-0.75	50 sample, 0.75mm thick	8ul	ME20-4-2	Prep 4, Marker 2, 2mm thick	306ul
			ME20-10-2	10 sample, 2mm thick	144ul
ME20-1-1	Prep 1, Marker 1, 1mm thick	675ul	ME20-16-2	16 sample, 2mm thick	81ul
ME20-2-1	Prep 2, Marker 2, 1mm thick	315ul	ME20-20MC-2	20 sample MC, 2mm thick	54ul
ME20-4-1	Prep 4, Marker 2, 1mm thick	153ul	ME20-25-2	25 sample, 2mm thick	42ul
ME20-10-1	10 sample, 1mm thick	72ul	ME20-30-2	30 sample, 2mm thick	34ul
ME20-16-1	16 sample, 1mm thick	41ul	ME20-36-2	36 sample, 2mm thick	29ul
ME20-20MC-1	20 sample MC, 1mm thick	27ul	ME20-40MC-2	40 sample MC, 2mm thick	23ul
ME20-25-1	25 sample, 1mm thick	21ul	ME20-50-2	50 sample, 2mm thick	21ul
ME20-30-1	30 sample, 1mm thick	17ul			
ME20-36-1	36 sample, 1mm thick	14ul	ME26-28MC-0.75	28 sample MC, 0.75mm thick	25ul
ME20-40MC-1	40 sample MC, 1mm thick	11ul	ME26-56MC-0.75	56 sample MC, 0.75mm thick	10ul
ME20-50-1	50 sample, 1mm thick	10ul	ME26-28MC-1	28 sample MC, 1mm thick	34ul
			ME26-56MC-1	56 sample MC, 1mm thick	14ul
ME20-1-1.5	Prep 1, Marker 1, 1.5mm thick	1013ul	ME26-28MC-1.5	28 sample MC, 1.5mm thick	51ul
ME20-2-1.5	Prep 2, Marker 2, 1.5mm thick	473ul	ME26-56MC-1.5	56 sample MC, 1.5mm thick	20ul
ME20-4-1.5	Prep 4, Marker 2, 1.5mm thick	230ul	ME26-28MC-2	28 sample MC, 2mm thick	68ul
ME20-10-1.5	10 sample, 1.5mm thick	108ul	ME26-56MC-2	56 sample MC, 2mm thick	27ul

## Midi96 plus-1 & Super plus Gel System

### ME-96 series ME-Level4

The Midi96 plus-1 Gel System is ideal for high throughput electrophoresis of PCR products or samples containing a small number of DNA bands. Its 100x120mm (WxL) gel dimension and 96-well comb block format correspond to the standard microplate configuration, with additional lanes for markers. Two different types of comb are available: one which has 8 wells and one additional lane for DNA markers and one which has 8 wells and 2 additional lanes for markers. The offset layout of the wells allows a maximum run length of 18mm per well, resulting in improved separation. Midi96 plus-1 can accommodate samples from a 96-well plate – samples can be loaded directly using 8-channel pipettes. As with all ME series units, leak-proof casting is simplified using the supplied casting dams while their ultra-compact size minimises buffer usage and bench space requirements. Midi96 plus-1 Stretch Systems are also available for those users requiring an extended run length per well of up to 36mm.

The ME-Level4 is a compact system capable of running a maximum 1200 samples simultaneously by stacking up to 4 horizontal gels. This achieves high sample throughput while maintaining the time- and space-saving advantages of a small, compact unit.

Each Super plus Gel System is supplied with 4 gel trays and 8 combs as standard, while additional trays and combs may be purchased as required. Two double-sided comb and three tray length formats are also available. An optional flexi caster, either supplied separately or as a package with the Super plus Gel System, is also available that allows up to four 80x60, 80x120 and 80x180mm gel trays to be cast simultaneously outside the tank.

#### For ME-96 series Features

- Designed for loading of DNA samples from multi-well plates
- Ideal for analysis of up to 96 PCR-fragment length polymorphisms loaded from 96-well microplates or thermal cycler blocks
- Average run-time is just 15 to 30 minutes
- Direct microplate format for easy lane identification
- Multichannel pipette compatible combs for speed loading

#### For ME-Level4 Features

- Separates a maximum 1200 samples in as little as 15 minutes in 4 stacked horizontal gel trays
- Multichannel-compatible combs and gel plate configurations compatible with microplates and thermal cycler blocks ensure rapid loading of DNA minipreps and PCR products by 8-channel pipette
- Double-sided 1.5-mm-thick combs allow more sample volume to be loaded into each well
- Three gel tray options available in 80x60, 80x120 and 80x180mm (WxL) sizes for maximum flexibility
- Small footprint area reduces uptake of bench space within the laboratory
- Ideal for rapid checking of large numbers of samples from PCR and cloning



Ideal for 96-well microplates or thermal cycler blocks



Capable of running a maximum 1200 samples by stacking up to 4 horizontal gel trays

## Specification

Cat. No.	ME-96	ME-96ST	ME-Level4
Gel Dimension (WxL)	3.9"x4.7" (100x120mm)	3.9"x9.5" (100x240mm)	3.2"x2.4" (80x60mm)(Optional) 3.2"x4.8" (80x120mm)(Optional) 3.2"x7.1" (80x180mm)
Dimension (WxLxH)	8.7"x4.9"x3.5" (220x125x90mm)	18.3"x4.9"x3.2" (465x125x80mm)	13.8"x4.3"x6.3" (350x110x160mm)
Buffer Volume	0.08gal (300ml)	0.18gal (700ml)	200, 400, 600 or 800ml for 1,2,3 or 4 gel trays respectively
Max. Sample Capacity Per 180mm Tray	96 samples plus 1 or 2 marker lanes		With 10mm run length: 306 With 20mm run length: 144 With 30mm run length: 72
Number Of Samples	8 + 1 x Marker, or 8 + 2 x Markers		1, 8, 12, 18 duocombs
Comb Thickness	0.04" or 0.06" (1 or 1.5mm)		

## Ordering Information

Cat. No.	Product Description
ME-96	Midi 96 plus-1, UV tray, comb block with 12x8 sample, 1mm thick combs, casting dams
ME-961.5	Midi 96 plus-1, UV tray, comb block with 12x8 sample, 1.5mm thick combs, casting dams. combs have one marker lane
ME-96/2M	Midi 96 plus-1, UV tray, comb block with 12x8 sample, 1mm thick combs, casting dams. combs have two marker lanes
ME-96/1.5/2M	Midi 96 plus-1, UV tray, comb block with 12x8 sample, 1.5mm thick combs, casting dams. combs have two marker lanes
ME-96ST	Midi 96 plus-2, UV tray, comb block with 12x8 sample, 1mm thick combs, casting dams
ME-96ST1.5	Midi 96 plus-2, UV tray, comb block with 12x8 sample, 1.5mm thick combs, casting dams. combs have one marker lane
ME-96ST/2M	Midi 96 plus-2, UV tray, comb block with 12x8 sample, 1mm thick combs, casting dams. combs have two marker lanes
ME-96ST/1.5/2M	Midi 96 plus-2, UV tray, comb block with 12x8 sample, 1.5mm thick combs, casting dams. combs have two marker lanes
ME-Level4	Super plus, multi-level gel chamber, includes 4x180mm UV trays, 8 x18/8 sample 1.5mm combs
ME-Level4/EXCAS	Super plus, as above but with external caster for 4 gels

## Accessories

Cat. No.	Product Description
ME-96-8-1-CB	Midi96 plus-1 Comb 8 sample MC+1 Marker, 1mm thick comb block
ME-96-8-1.5-CB	Midi96 plus-1 Comb 8 sample MC+1 Marker, 1.5mm thick comb block
ME-96-8-1/2M-CB	Midi96 plus-1 Comb 8 sample MC+2 Markers, 1mm thick comb block
ME-96-8-1.5/2M-CB	Midi96 plus-1 Comb 8 sample MC+2 Markers, 1.5mm thick comb block
ME-96ST-8-1-CB	Midi96 plus-2 Comb 8 sample MC+1 Marker, 1mm thick comb block
ME-96ST-8-1.5-CB	Midi96 plus-2 Comb 8 sample MC+1 Marker, 1.5mm thick comb block
ME-96ST-8-1/2M-CB	Midi96 plus-2 Comb 8 sample MC+2 Markers, 1mm thick comb block
ME-96ST-8-1.5/2M-CB	Midi96 plus-2 Comb 8 sample MC+2 Markers, 1.5mm thick comb block
ME-96-8-1	Midi96 plus-1 Comb 8 sample MC, 1mm thick. one Marker lane
ME-96-8-1.5	Midi96 plus-1 Comb 8 sample MC, 1.5mm thick. one Marker lane
ME-96-8-1/2M	Midi96 plus-1 Comb 8 sample MC, 1mm thick. two Marker lanes
ME-96-8-1.5/2M	Midi96 plus-1 Comb 8 sample MC, 1.5mm thick. two Marker lanes
ME10-UV96	Midi plus-1, 96 well tray
ME10-UV96ST	Midi plus-1 STRETCH, 96 well tray
ME-L4-UV6	80x60mm tray
ME-L4-UV12	80x120mm tray
ME-L4-UV18	80x180mm tray
ME-L4-EXCASTER	External caster for ME-Level4 (4 Trays)
ME-L4-12/1-1	12/1 sample 1mm combs
ME-L4-18/8-1	18/8 sample 1mm combs
ME-L4-12/1-1.5	12/1 sample 1.5mm combs
ME-L4-18/8-1.5	18/8 sample 1.5mm combs



# Mini Vertical Gel Electrophoresis Apparatus

## MV-10DSYS

Mini Vertical is an injection molded vertical electrophoresis system providing a leak-proof environment and safe operation. Its vertical tank is designed for blotting compatibility. The dual 100x100mm plate is the most popular application and it is capable of handling up to 4 plates. In addition, packages with Mini 300V Power supply is ideally offered to individuals in the laboratory at a competitive and acceptable pricing to avoid time waiting for basic instruments and to accelerate experimental progress. Simple rapid and leak-proof gel casting.

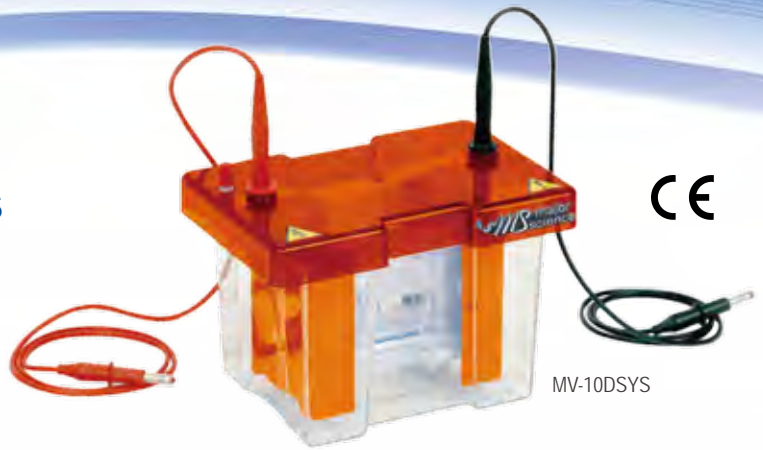

MV-10DSYS

This product is offered as a complete system for the user to cast, and run electrophoresis. including:

- 1 x Electrophoresis tank & lid & inner running module
- 1 x MV-10NG (100x100mm notched glass plates, 2mm thick, pk/2)
- 1 x MV-10PGS1 (100x100mm plain glass plates with 1mm bonded spacers, pk/2)
- 1 x MV-10DP (dummy plate)
- 2 x MV-10-12-1 (12 sample combs, 1mm thick)
- 1 x MV-10DCAST (100x100mm casting base)
- 1 x MV 10ICB (mini cooling pack)
- 1 x MS-DAG-GT01 (sillcone water repellent spray 5ml)
- 1 x Black & red electrophoresis cable



1

Insert glass plates and slide gates to create efficient seal.



2

Transfer to casting base and tighten cams.



3

It is best to turn the cams in opposite directions to each other.



4

Pour gel solution, insert combs and allow gel to polymerize.

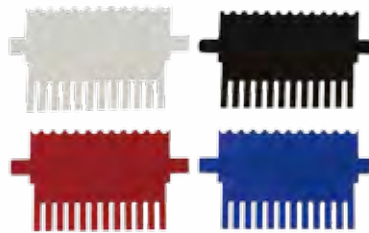

Extensive range of combs  
 Black: 0.75mm for ultra resolved bands  
 White: 1mm supplied as standard  
 Red: 1.5mm for large sample volume  
 Blue: 2mm for large sample volume



5

Transfer to tank, fill with buffer and run.



MC = Multi-channel pipette compatible



\* If your want to run 4 gels, a set of notched glass plate and also bonded spacer would be required to buy separately.

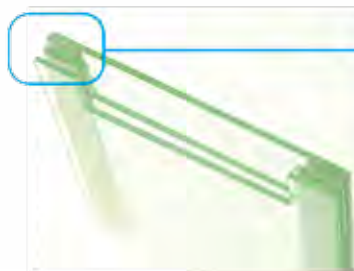

**MV-10DSYS**

is capable to run up to 4 gels when using a triple glass plate sandwich.



MV10-Mini300

### Features

- Low buffer consumption
- Single molded tank
- Up to 4 gels run at one time
- Great indications for gel making and running
- Ice cooling pack
- Easy gel casting and no gel leakage
- Competitive pricing
- Compatible with all precast gels (100x100mm or 100x80mm)

## Specification

Cat. No.	MV-10DSYS
Dimension (WxLxH)	Approx. 7.5"x5.1"x5.9" (190x130x150mm)
Plate Dimension (WxL)	Approx. 3.9" 3.9" (100x100mm)
Gel Dimension (WxL)	Approx. 3.4"x3.2" (85x80mm)
Maximum Sample	80 samples, 20 samples per gel
Buffer Volume	0.07gal -0.32gal (250 -1200ml)
Ice Cooling Pack	Yes
Dummy Plate And Casting Base	Yes
Construction	Injection molded construction
	Durable, leak proof environment for complete safety and long life
Electrical Safety	Lid can be fastened in only one way
	Upon lid removal, power is disconnected from buffer chamber
Rapid Casting Gel	Use gel maker stand

## Ordering Information

Cat. No.	Product Description
MV-10DSYS	Complete Mini Vertical Gel Electrophoresis Apparatus
	Mini 100x100mm Dual, 2 sets of glass plates with 1mm thick bonded spacers
	2x12 sample, 1mm thick combs, cooling pack, dummy plate and casting base
MV10-Mini300	Package of MV-10DSYS and MINI-300
MV10EXCASTERSYS	External Casting System, upstand + base
MV10EXCASTER	External Casting Upstand - no casting base
MV-10DCAST	100x100mm casting base
MV-10DCASTM	Replacement Silicone Mat for 100x100mm casting base
MV-10DIRM	Inner running module
MV-10LID	MV-10 lid (No cables)
MV-10TANK	MV-10 tank
MV-10ICB	Mini cooling pack
MV-10PG	100x100mm plain glass plates, 2mm thick (pk/2)
MV-10PGS0.75	100x100mm plain glass plates with 0.75mm bonded spacers (pk/2)
MV-10PGS1	100x100mm plain glass plates with 1mm bonded spacers (pk/2)
MV-10PGS1.5	100x100mm plain glass plates with 1.5mm bonded spacers (pk/2)
MV-10PGS2	100x100mm plain glass plates with 2mm bonded spacers (pk/2)
MV-10NG	100x100mm notched glass plates, 2mm thick (pk/2)
MV-10NGS0.75	100x100mm notched glass plates with 0.75mm bonded spacers (pk/2)
MV-10NGS1	100x100mm notched glass plates with 1mm bonded spacers (pk/2)
MV-10NGS1.5	100x100mm notched glass plates with 1.5mm bonded spacers (pk/2)
MV-10NGS2	100x100mm notched glass plates with 2mm bonded spacers (pk/2)
MV-10DP	Dummy plate, 100x100mm
MV-10S0.75	100mm spacers - 0.75mm (pk/2)
MV-10S1	100mm spacers -1mm (pk/2)
MV-10S1.5	100mm spacers - 1.5mm (pk/2)
MV-10S2	100mm spacers - 2mm (pk/2)



MV10EXCASTER

## Accessories

MC = Multi-channel pipette compatible

SV = Sample volume for 5mm thick gel (ul)

Cat. No.	Product Description	SV
MV-10-1-0.75	Comb 1 Prep, 1 Marker, 0.75mm thick	500ul
MV-10-5-0.75	Comb 5 sample, 0.75mm thick	70ul
MV-10-8MC-0.75	Comb 8 sample MC, 0.75mm thick	40ul
MV-10-9-0.75	Comb 9 sample, 0.75mm thick	35ul
MV-10-10-0.75	Comb 10 sample, 0.75mm thick	30ul
MV-10-12-0.75	Comb 12 sample MC, 0.75mm thick	25ul
MV-10-16MC-0.75	Comb 16 sample MC, 0.75mm thick	20ul
MV-10-20-0.75	Comb 20 sample, 0.75mm thick	15ul
MV-10-1-1	Comb 1 Prep, 1 Marker, 1mm thick	650ul
MV-10-5-1	Comb 5 sample, 1mm thick	100ul
MV-10-8MC-1	Comb 8 sample MC, 1mm thick	60ul
MV-10-9-1	Comb 9 sample, 1mm thick	50ul
MV-10-10-1	Comb 10 sample, 1mm thick	40ul
MV-10-12-1	Comb 12 sample, 1mm thick	35ul
MV-10-16MC-1	Comb 16 sample MC, 1mm thick	25ul
MV-10-20-1	Comb 20 sample, 1mm thick	20ul

Cat. No.	Product Description	SV
MV-10-1-1.5	Comb 1 Prep, 1 Marker, 1.5mm thick	1000ul
MV-10-5-1.5	Comb 5 sample, 1.5mm thick	140ul
MV-10-8MC-1.5	Comb 8 sample MC, 1.5mm thick	80ul
MV-10-9-1.5	Comb 9 sample, 1.5mm thick	70ul
MV-10-10-1.5	Comb 10 sample, 1.5mm thick	30ul
MV-10-12-1.5	Comb 12 sample MC, 1.5mm thick	50ul
MV-10-16MC-1.5	Comb 16 sample MC, 1.5mm thick	40ul
MV-10-20-1.5	Comb 20 sample, 1.5mm thick	30ul
MV-10-1-2	Comb 1 Prep, 1 Marker, 2mm thick	1300ul
MV-10-5-2	Comb 5 sample, 2mm thick	200ul
MV-10-8MC-2	Comb 8 sample MC, 2mm thick	120ul
MV-10-9-2	Comb 9 sample, 2mm thick	100ul
MV-10-10-2	Comb 10 sample, 2mm thick	80ul
MV-10-12-2	Comb 12 sample, 2mm thick	70ul
MV-10-16MC-2	Comb 16 sample MC, 2mm thick	50ul
MV-10-20-2	Comb 20 sample, 2mm thick	40ul

# Mini Wide / Maxi Plus Vertical Gel Electrophoresis Apparatus

## MV-10WDSYS MV-30DSYS

Mini Wide Vertical Electrophoresis System (MV-10WDSYS) with a gel width of 200mm effectively doubles the number of samples that can be resolved when compared to the Mini Vertical Electrophoresis System. This allows consistency of sample comparison on a single gel and is designed for those with greater than 20 samples to compare and resolve. Simple set up using ultra soft silicone seals guarantees trouble free glass plate loading and gel casting. Dual gaskets on the gel running insert along with notched and plain glass plates ensure leak proof gel running. Rapid set up cooling retains resolution in extended separations and also saves buffer volume without affecting run quality. 4mm thick glass plates reduce breakage and have bonded spaces for added convenience. A wide range of accessories are available to allow for many techniques to be performed using the same unit. Prep combs can be used to maximize sample loading and recovery.

The Maxi Plus Vertical Electrophoresis System (MV-30DSYS) is a large format vertical unit for running large quantities of samples at once. It is also designed as a convenient, large format vertical unit for second-dimension PAGE following first-dimension isoelectric focusing using the MIEF system.



Mini wide system uses same combs as MV-20WAVESYS System

### For MV-10WDSYS Features

- Offers the capacity of two mini gels on a single gel
- Rapid gel casting and loading
- Low buffer consumption
- Run up to 4 gels at one time
- Great indications for gel making and running
- Ice cooling pack
- Easy gel casting and no gel leakage
- Competitive pricing

### For MV-30DSYS Features

- Ideal for second-dimension electrophoresis
- Accepts IPG strips 240mm in length, the longest available commercially
- Rapid set-up cool packs enhance resolution, particularly during extended runs



MV-10WDSYS 

### MV-10WDSYS

This product is offered as a complete system for the user to cast, and run electrophoresis. It including:

- 1 x Electrophoresis tank & lid & inner running module
- 1 x MV-10WNG (200x100mm notched glass plates, 2mm thick, pk/2)
- 1 x MV-10WPGS1 (200x100mm plain glass plates with 1mm bonded spacers, pk/2)
- 1 x MV-10WDP (dummy plate)
- 2 x MV-20-24-1 (24 sample combs, 1mm thick)
- 1 x MV-20DCAST (200x100mm casting base)
- 1 x MV-20ICB (mini cooling pack)
- 1 x MS-DAG-GT01 (silicone water repellent spray 5ml)
- 1 x Black & red electrophoresis cable



MV-30DSYS 



## Specification

Cat. No.	MV-10WDSYS
Dimension (WxLxH)	Approx. 10.2"x6.3"x6.3" (260x160x160mm)
Plate Dimension (WxL)	Approx. 7.9"x3.9" (200x100mm)
Gel Dimension (WxL)	Approx. 7.1"x3.2" (180x80mm)
Maximum Sample	192 samples, 48 samples per gel
Buffer Volume	0.16gal - 0.74gal (600 - 2800ml)
Ice Cooling Pack	Yes
Dummy Plate And Casting Base	Yes
Electrical Safety	Lid can be fastened in only one way Upon lid removal, power is disconnected from buffer chamber
Rapid Casting Gel	Use gel maker stand
Cat. No.	MV-30DSYS
Dimension (WxLxH)	Approx. 14.2"x7.1"x13" (360x180x330mm)
Plate Dimension (WxL)	Approx. 11.8"x8.7" (300x220mm)
Gel Dimension (WxL)	Approx. 11"x7.9" (280x200mm)
Max. Sample Capacity	300 samples per run; 75 per gel
Buffer Volume	0.48 - 2.22gal (1800 - 8400ml)
Comb Options	
Number Of Teeth	1, 2, 4, 28 MC, 56 MC, 75
Thicknesses	0.75, 1, 1.5, 2mm

## Ordering Information

Cat. No.	Product Description
MV-10WDSYS	Mini Wide Vertical Gel Electrophoresis Apparatus
	Mini Wide 200x100mm Dual, 2 sets of glass plates with 1mm thick bonded spacer
	2x24 sample, 1mm thick combs, cooling pack, dummy plate and casting base
MV-30DSYS	Maxi Plus Vertical Electrophoresis System with base unit
MV-20DCAST	Maxi casting base for MV-10WDSYS & MV-20WAVESYS
MV-20DCASTM	Replacement rubber mat for 200x100mm casting base
MV-10WDIRM	Inner running module
MV-20ICB	Maxi cooling pack
MV-10WLID	MV-10W lid (No cables)
MV-10WTANK	MV-10W Tank
MV-10WNG	200x100mm notched glass plates, 4mm thick (pk/2)
MV-10WPG	200x100mm plain glass plates, 4mm thick (pk/2)
MV-10WPGS0.75	200x100mm plain glass plates with 0.75mm bonded spacers (pk/2)
MV-10WPGS1	200x100mm plain glass plates with 1mm bonded spacers (pk/2)
MV-10WPGS1.5	200x100mm plain glass plates with 1.5mm bonded spacers (pk/2)
MV-10WPGS2	200x100mm plain glass plates with 2mm bonded spacers (pk/2)
MV-10WNGS0.75	200x100mm notched glass plates with 0.75mm bonded spacers (pk/2)
MV-10WNGS1	200x100mm notched glass plates with 1mm bonded spacers (pk/2)
MV-10WDP	Dummy plate, 200x100mm

## Optional Combs \*For MV-10WDSYS optional combs, please refer to P39

Cat. No.	Product Description	Sample Volume
MV-30-1-1	Comb 1 Prep, 1 Marker, 1mm thick	2250ul
MV-30-2-1	Comb 2 samples, 1mm thick	1125ul
MV-30-4-1	Comb 4 samples, 1mm thick	550ul
MV-30-28MC-1	Comb 28 samples, 1mm thick MC compatible	80ul
MV-30-56MC-1	Comb 56 samples, 1mm thick MC compatible	40ul
MV-30-75-1	Comb 75 samples, 1mm thick	25ul
MV-30-1-1.5	Comb 1 Prep, 1 Marker, 1.5mm thick	3375ul
MV-30-2-1.5	Comb 2 samples, 1.5mm thick	1680ul
MV-30-4-1.5	Comb 4 samples, 1.5mm thick	825ul
MV-30-28MC-1.5	Comb 28 samples, 1.5mm thick MC compatible	120ul
MV-30-56MC-1.5	Comb 56 samples, 1.5mm thick MC compatible	60ul
MV-30-75-1.5	Comb 75 samples, 1.5mm thick	37ul

# Maxi WAVE Vertical Electrophoresis System

## MV-20WAVESYS

The Maxi WAVE Vertical Electrophoresis System is our latest product innovation for large-format vertical gel electrophoresis. Designed to perform a variety of separations, including first-and second-dimension SDS-PAGE, native, preparative, gradient and high-resolution nucleic acid electrophoresis, plus capillary tube gel IEF and electroblotting, the MV-20WAVESYS is one of the most versatile maxi vertical systems available.

By introducing innovative, new vertical screw-clamp technology within the PAGE insert only four screws are now necessary to secure as many 20x20 gels. This gives the MV-20WAVE system the elective advantage of a much faster set up speed compared to competitor products whose traditional clamping configurations require as many as 24 screws to secure just two glass plates.

In addition, the WAVE's vertical screw-clamp configuration distributes pressure evenly along the height of the gel rather than in the center to eliminate plate bowing and gel compression, but still maintains a leak-proof seal during casting; while the ergonomic wave-like design of the PAGE insert aids both handling and set up.



Pakage of MINI-500 + MV-20WAVESYS

### Features

- **More gels** run 2 to 4 gels simultaneously
- **Customize your system** for second-dimension runs with 180mm IPG strips and gels using the IEF conversion kit
- **Utilize modular inserts** with the same universal tank and lid to extend the application of your standard WAVE unit to create a complete 2-D or blotting system.
- **Vertical screw** clamps distribute pressure evenly along the height of the gel to prevent plate bowing and gel compression
- **Glass plates compress** gently against a flat, level gasket to prevent current leakage from the inner buffer chamber during electrophoresis
- Detachable inner cooling coil connects to the laboratory water supply or a recirculating chiller to provide uniform, smile-free electrophoresis, while allowing runs to be performed at higher voltage
- Deep gel tank with adequate clearance beneath the glass plates to allow a magnetic stirrer to maintain buffer recirculation and uniform pH
- Dual purpose PAGE insert eliminates time-consuming transfer of glass plates between separate casting and running modules
- Ground glass plates with bonded injection moulded spacers consistent with comb thickness ensure "clean" well formation, as well as the correct alignment for leak-free casting; also eliminate the need for easily mislaid and awkward to use spacer aligners
- Ultra-soft silicone mat within cam-caster compensates for glass plate misalignment to ensure leak-free casting
- Widest selection of combs allow separation of up to 192 samples
- Asymmetric lid design and color-coded screw pins in PAGE insert prevent polarity reversal



MV-20WAVESYS

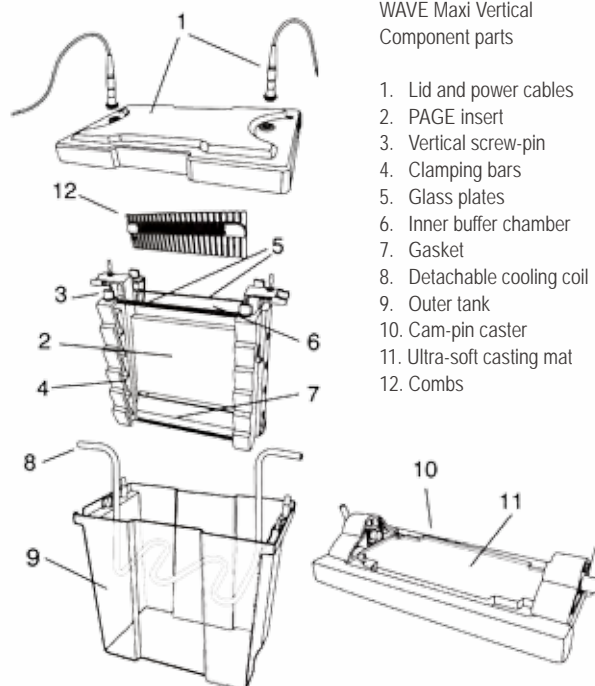

WAVE Maxi Vertical Component parts

1. Lid and power cables
2. PAGE insert
3. Vertical screw-pin
4. Clamping bars
5. Glass plates
6. Inner buffer chamber
7. Gasket
8. Detachable cooling coil
9. Outer tank
10. Cam-pin caster
11. Ultra-soft casting mat
12. Combs

### Specification

Cat. No.	MV-20WAVESYS
Dimension (WxLxH)	Approx. 11.8"x7.1"x10.9" (300x180x270mm)
Plate Dimension (WxL)	Approx. 7.9"x7.9"x0.2" (200x200x4mm)
Gel Dimension (WxL)	Approx. 6.3"x6.9" (160x175mm)
Maximum Sample	192 samples, 48 samples per gel
Total Buffer Volume	4.8-5.3L
Total Volume Inner Buffer Chamber	640ml
Cooling Method	Cooling coil
Dummy Plate And Casting Base	Yes
Construction	Injection molded construction
	Durable, leak proof environment for complete safety and long life
Electrical Safety	Lid can only be fastened in one way
	On removal, power is disconnected from buffer chamber
Rapid Casting Gel	Use casting dams

## Ordering Information

Cat. No.	Product Description
MV-20WAVESYS	Complete Maxi WAVE Vertical Gel Electrophoresis Apparatus, Maxi WAVE 200x200mm Dual, sets of glass plates with 1mm thick bonded spacers, 2x24 sample, 1mm thick combs, cooling coil, dummy plate and casting base
<b>Bundle Packages</b>	
Mini500-CP-03	Package of Mini-500 and MV-20WAVESYS
<b>Accessories</b>	
MV-20WAVE-EC	MV20 WAVE External Casting Stand - No Casting Base
MV-20WAVECAST	MV20WAVE Casting Base
MV-20WAVEDIRM	MV20wave Page insert
MV-20WAVE-CC	Detachable Cooling Coil
MV-20DCAST	Maxi, casting base for MV-10WDSYS and MV-20DSYS
MV-20DCASTM	Replacement Rubber mats for MV-10WDSYS and MV-20DSYS casting base
MV-20DIRM	Maxi, Inner Running Module
MV-20ICB	Maxi Cooling Block.
MV-20LID	MV-20 lid (No cables)
MV-20TANK	MV-20 Tank
MV-20NG	20 x 20cm Notched Glass Plates 4mm thick ( Pack of 2)
MV-20PG	20 x 20cm Plain Glass Plates 4mm thick ( Pack of 2)
MV-20PGS0.75	20 x 20cm Plain Glass Plates with 0.75mm Bonded Spacers (Pack of 2)
MV-20PGS1	20 x 20cm Plain Glass Plates with 1mm Bonded Spacers ( Pack of 2)
MV-20PGS1.5	20 x 20cm Plain Glass Plates with 1.5mm Bonded Spacers (Pack of 2)
MV-20PGS2	20 x 20cm Plain Glass Plates with 2mm Bonded Spacers (Pack of 2)
MV-20NGS0.75	20 x 20cm Notched Glass Plates with 0.75mm Bonded Spacers (Pack of 2)
MV-20NGS1	20 x 20cm Notched Glass Plates with 1mm Bonded Spacers ( Pack of 2)
MV-20DP	Dummy Plate, 20 x 20cm
MV-20S0.75	20cm Spacers - 0.75mm (Pack of 2)
MV-20S1	20cm Spacers - 1mm thick (Pack of 2)
MV-20S1.5	20cm Spacers - 1.5mm thick (Pack of 2)
MV-20S2	20cm Spacers - 2mm thick (Pack of 2)
<b>Optional combs</b>	
MV-20-1-0.75	Comb 1 Prep, 1 Marker, 0.75mm thick
MV-20-5-0.75	Comb 5 sample, 0.75mm thick
MV-20-10-0.75	Comb 10 sample, 0.75mm thick
MV-20-18MC-0.75	Comb 18 sample MC, 0.75mm thick
MV-20-24-0.75	Comb 24 sample, 0.75mm thick
MV-20-30-0.75	Comb 30 sample, 0.75mm thick
MV-20-36MC-0.75	Comb 36 sampl MC, 0.75mm thick
MV-20-48-0.75	Comb 48 sample, 0.75mm thick
MV-20-1-1	Comb 1 Prep, 1 Marker, 1mm thick
MV-20-5-1	Comb 5 sample, 1mm thick
MV-20-10-1	Comb 10 sample, 1mm thick
MV-20-18MC-1	Comb 18 sample MC, 1mm thick
MV-20-24-1	Comb 24 sample, 1mm thick
MV-20-30-1	Comb 30 sample, 1mm thick
MV-20-36MC-1	Comb 36 sampl MC, 1mm thick
MV-20-48-1	Comb 48 sample, 1mm thick
MV-20-1-1.5	Comb 1 Prep, 1 Marker, 1.5mm thick
MV-20-5-1.5	Comb 5 sample, 1.5mm thick
MV-20-10-1.5	Comb 10 sample, 1.5mm thick
MV-20-18MC-1.5	Comb 18 sample MC, 1.5mm thick
MV-20-24-1.5	Comb 24 sample, 1.5mm thick
MV-20-30-1.5	Comb 30 sample, 1.5mm thick
MV-20-36MC-1.5	Comb 36 sampl MC, 1.5mm thick
MV-20-48-1.5	Comb 48 sample, 1.5mm thick
MV-20-1-2	Comb 1 Prep, 1 Marker, 2mm thick
MV-20-5-2	Comb 5 sample, 2mm thick
MV-20-10-2	Comb 10 sample, 2mm thick
MV-20-18MC-2	Comb 18 sample MC, 2mm thick
MV-20-24-2	Comb 24 sample, 2mm thick
MV-20-30-2	Comb 30 sample, 2mm thick
MV-20-36MC-2	Comb 36 sampl MC, 2mm thick
MV-20-48-2	Comb 48 sample, 2mm thick

SV = Sample volume for 5mm thick gel (ul)



## Complete Mini / Mini Wide / Maxi Electro Blot System

## Complete Mini / Mini Wide / Maxi Sub Blot System

MEBM10 / MEBM20 / MSB10 / MSB10W / MSB20  
MV-10CBS / MV-10WCBS  
MV-20CBS

Electro Blot Systems are primarily designed for wet electrophoresis of proteins, and offer a combination of increased capacity with economical features. Electro Blot Systems have increased capacity over standard systems. Up to five gel blot cassettes may be utilized at any time for Electro Blot Mini and Maxi, and up to three gel cassettes can be utilized for Electro Blot Mini Wide. This is especially useful in high throughput laboratories. A uniform electric field is provided by a high intensity coiled electrode and ensures uniform transfer across the blot surface. The cassette's open architecture that ensures the maximum blot area allows direct transfer of current. Its rigid construction that ensures contact between the gel and membrane is retained throughout the blot and an even pressure is maintained. These units are compatible with magnetic stirrers to aid heat dispersal and prevent pH drifts in the buffer due to incomplete buffer mixing. Each unit includes a cooling pack to further enhance transfer efficiency by removing excess heat. This also saves buffer for added economy.

The Complete Electrophoresis Systems include both modules for gel electrophoresis, electroblotting and accessories, to provide a complete Mini, Mini Wide or Maxi gel casting, running and electroblotting system. The electroblotting module includes three inter-locking cassettes and six fiber pads. A high intensity current is generated by coiled platinum electrodes. These features, in conjunction with the advanced cooling system allow for rapid electroblotting in as little as one hour.

### For MEBM series Features

- Ideal for wet electroblotting of proteins – Western Blotting
- Hinged cassettes for added convenience
- Accommodates gel thickness from 0.25 to 3mm

### For MV-CBS series Features

- Versatile: Interchangeable modules for slab gel and Electroblotting using a single universal buffer tank
- Hinged cassettes
- High intensity electrodes
- 3 or 4 blot capacity depending on the model
- Rapid set-up cooling

### Mini / Mini Wide / Maxi Electro Blot System

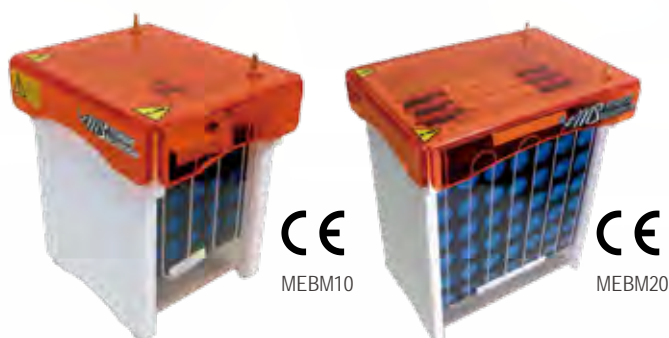

### Complete Mini / Mini Wide / Maxi Electro & Blot System

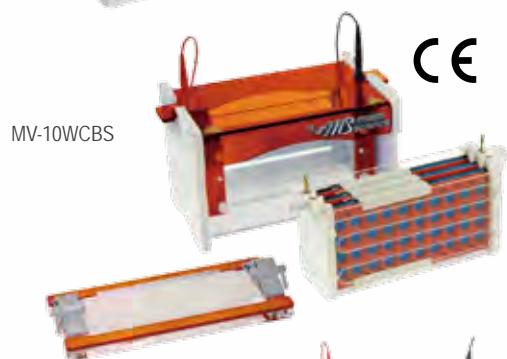

## Specification

Cat. No.	MEBM10	MSB10W	MEBM20
Dimension (WxLxH)	7.5"x5.1"x7.5" (190x130x190mm)	10.2"x6.3"x6.3" (260x160x160mm)	9.5"x6.3"x10.2" (240x160x260mm)
Gel Dimension (WxL)	3.9"x3.9" (100x100mm)	7.9"x 3.9" (200x100mm)	7.9"x7.9" (200x200mm)
Maximum Sample	5 Blots, 100x100mm	3 Blots, 200x100mm	5 Blots, 200x200mm 20 Blots, 100x100mm
Accomodate Gel Thickness	0.25 - 3mm	0.25 - 3mm	0.25 - 3mm
Buffer Volume	1000 - 1500ml	2800ml max.	4300 - 6000ml
Ice Cooling Pack	Yes		
Construction	Durable, leak proof environment for complete safety and long life		
Electrical Safety	Lid can only be fastened in one way		
	On removal, power is disconnected from buffer chamber		
Cassette Type	Hinged cassette		

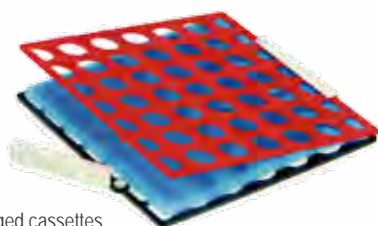
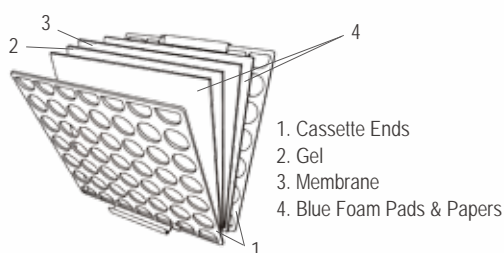

Double hinged cassettes for added convenience

## Ordering Information

Cat. No.	Product Description
MEBM10	Electro Blot Mini, 100x100mm system for 5 cassettes, including 1 x tank and 1 x lid, 5 x cassettes, cooling pack and 16 extra fiber pads
MEBM20	Electro Blot Maxi, 200x200mm system for 5 cassettes, including 1 x tank and 1 x lid, 5 x cassettes, cooling pack and 12 extra fiber pads
MSB10	Sub Blot Mini, 100x100mm system for 4 cassettes, including 1 x tank and 1 x lid, 4 x cassettes, cooling pack and 16 extra fiber pads
MSB10W	Sub Blot Mini Wide, 200x100mm system for 4 cassettes, including 1 x tank and 1 x lid, 4 x cassettes, cooling pack and 16 extra fiber pads
MSB20	Sub Blot Maxi, 200x200mm system for 4 cassettes, including 1 x tank and 1 x lid, 4 x cassettes, cooling pack, cooling coil and 18 extra fiber pads
MSB10C	Blot Mini cassette
MSB10WC	Blot Mini Wide cassette
MSB20C	Blot Maxi cassette
MSB10F	Fiber pads for Blot Mini - pack of 6
MSB10WF	Fiber pads for Blot Mini Wide - pack of 6
MSB20F	Fiber pads for Blot Maxi - pack of 6
MV10BI	Blot Mini Insert - including 4 cassettes and 16 fibre pads
MV10WBI	Blot Mini Wide Insert - including 3 cassettes and 12 fibre pads
MV20BI	Blot Maxi, Insert - including 3 cassettes and 12 fibre pads

MV-10CBS	Complete system for Mini Vertical Electrophoresis & Blotting, comprising:
	1x Mini Vertical unit, including:
	2x2mm thick notched glass plates
	2x2mm thick plain plates with 1mm thick bounded spacers, 1 x dummy plate
MV-10WCBS	2 x combs(1mm thick,12 samples), 1 x casting base, silicone mat, cooling pack
	1 x Electroblotting module, including:
	1 x Internal electroblotting module
	4 x Compression cassette for gel size up to 100x100mm, 16 x fiber pads
MV-20CBS	Complete system for Mini Wide Vertical Electrophoresis & Blotting, comprising:
	1 x Mini Wide Vertical unit, including:
	2x4mm thick notched glass plates
	2x4mm thick plain plates with 1mm thick bounded spacers, 1 x dummy plate
	2 x combs (1mm thick, 24 samples), 1 x casting base, silicone mat, cooling pack
	1 x Electroblotting module, including:
	1 x Internal electroblotting module
	4 x Compression cassette for gel size up to 200x100mm, 16 x fiber pads
MV-20CBS	Complete system for Maxi Vertical Electrophoresis & Blotting, comprising:
	1 x Maxi Vertical unit, including:
	2x4mm thick notched glass plates
	2x4mm thick plain plates with 1mm thick bounded spacers, 1 x dummy plate
	2 x combs(1mm thick, 24 samples), 1 x casting base, silicone mat, cooling pack
	1 x Electroblotting module, including:
	1 x Internal electroblotting module
	4 x Compression cassette for gel size up to 200x200mm, 18 x fiber pads

## Semi Dry Mini / Semi Dry Midi

### MSD series

Semi Dry Mini offers rapid transfer times for DNA, RNA and protein blotting, typically 15 to 30 minutes. It can be used for all types of blotting, including Western, Southern and Northern blots. It features an uncomplicated buffer and set up procedure and is compatible with gel thickness from 0.25 up to 10mm. The unit is compatible with its respective vertical electrophoresis system. It only requires very low buffer volume, typically only a few milliliters of buffer per transfer. A screw down lid secures the blot sandwich and allows complete control of pressure ensuring even transfer. The electrodes, comprising of a platinum coated anode and stainless steel cathode, will exhibit practically no corrosion and provides many years of trouble free use. Uniform heat dispersion across the blot sandwich ensures stable transfer times and prevents heat induced sample loss or transfer distortions. It also allows viewing of the blot sandwich to ensure correct positioning and transfer is occurring correctly. Electrode plates are fully separated to prevent arcing or damage.

#### Features

- Low buffer consumption
- Rapid transfer time
- Western, Southern and Northern blots
- Screw down lid – Gels from 0.25 up to 10mm thick
- Uniform heat dispersion
- Long life electrodes



Semi Dry Mini and Semi Dry Midi

#### Specification

Cat. No.	MSD10	MSD20
Dimension (WxLxH)	Approx. 6.3"x6.3"x2.8" (160x160x70mm)	Approx. 10.2"x10.2"x2.8" (260x260x70mm)
Gel Dimension (WxL)	Approx. 3.9"x3.9" (100x100mm)	Approx. 7.9"x7.9" (200x200mm)
Maximum Sample	1 Blot, 80x85mm	1 Blot, 160x175mm 2 Blots, 160x85mm 4 Blots, 80x85mm
Buffer Volume	5ml	20ml
Accomodate Gel Thickness	0.25-10mm	
Economic Transfer	Yes	
Construction	Durable, leak proof environment for complete safety and long life	

#### Ordering Information

Cat. No.	Product Description
MSD10	Semi Dry Mini, 100x100mm System
MSD20	Semi Dry Midi, 200x200mm System



# Comet Assay Tanks

## MCOM series

The Comet Assay Tanks are available in three slide formats to study single cell gel electrophoresis (SCGE), a technique made popular by drug toxicology and carcinogenesis studies for the detection and quantitation of DNA damage in cells. Each tank's robust construction from ebony acrylic ensures that cells remain free of exposure to background light and DNA damage during electrophoresis, while a cooled central platform provides a convenient surface for slide preparation and control of slide temperature during the assay.

### Features

- For single cell gel electrophoresis
- Minimise exposure to light and reduce background DNA damage
- High efficiency cooling for enhanced resolution samples from PCR and cloning

### Specification

Cat. No.	MCOM10	MCOM20	MCOM40
Slide Capacity	10	20	40
Dimension (WxLxH)	Approx. 6.7"x13.4"x3.5" (170x340x90mm)	Approx. 12.2"x13.4"x3.5" (310x340x90mm)	Approx. 13"x23.2"x3.5" (330x590x90mm)
Volume	0.15gal (550ml)	0.26gal (1000ml)	0.55gal (2100ml)
Recommended Running Conditions	25V / 300mA for 1h		



MCOM series

### Ordering Information

Cat. No.	Product Description
MCOM10	Comet Assay Tank for 10 Slides
MCOM20	Comet Assay Tank for 20 Slides
MCOM40	Comet Assay Tank for 40 Slides



# Dot and Slot Blotters

## MDHM series MSHM series

Four different sample number of hybridization manifolds are available: two types of dot blotters and two types of slot blotters. Typical applications include clone screening with DNA / RNA probes in Southern / Northern blots and immunological screening with antibodies in Western blots. Those units incorporate precision lapped surfaces to ensure uniform blotting membrane contact and a leak-proof gasket. These prevent lateral transfer of samples and smudging by ensuring that a complete vacuum is formed. Six thumbscrews ensure even and tight sealing for fastening samples. Dot blotters are available in 48 and 96 well versions and slot blotters in 24 and 48 well.

### Features

- Low cost
- Simple construction
- Easy assembly
- Four sample configuration
- Alpha-numeric sample identification

### Specification

Cat. No.	MDHM-48	MDHM-96	MSHM-24	MSHM-48
Dimension (WxLxH)	Approx. 2.4"x3.7"x3.9" (60x95x100mm)	Approx. 2.4"x4.1"x5.5" (60x105x140mm)	Approx. 2.4"x2.9"x3.3" (60x74x83mm)	Approx. 2.4"x3.7"x3.9" (60x95x100mm)
Membrane Size Required	Approx. 4.8"x1.7" (121x44mm)	Approx. 4.3"x2.9" (110x74mm)	Approx. 4.8"x1.7" (121x44mm)	Approx. 4.8"x1.7" (121x44mm)
Configuration	3x16	8x12	2x12	3x16
Size Of Well	6mm diameter, 12mm deep		6x0.5mm, 12mm deep	
Vacuum Required	600mg Hg 0.8 BAR with cold trap		600mg Hg 0.8 BAR with cold trap	



### Ordering Information

Cat. No.	Product Description
MDHM-48	48-Well Dot Blot
MDHM-96	96-Well Dot Blot
MSHM-24	24-Well Slot Blot
MSHM-48	48-Well Slot Blot

Dot Blotter

Slot Blotter

# Clinical Electrophoresis

## Cellulose Acetate Electrophoresis

### ME-CELLAS

Cellulose Acetate Electrophoresis is an important technique in clinical diagnostics. This new range of cellulose acetate products offers a complete system solution for research and clinical cellulose acetate electrophoresis procedures. The Cellulose Acetate System is the ideal tank for both standard and wet cellulose acetate electrophoresis. This unit is designed for both routine and research requirements and is built to our high quality standard. The unit includes an adjustable support which enables easy and fast adjustment for different lengths of cellulose acetate strip.

Cellulose Acetate Gels – a new complete range of wet cellulose acetate gels is available. These have the advantage that they can be used for a wide variety of clinical electrophoresis applications including haemoglobin, serum proteins for monoclonal gammopathies, urine proteins, isoenzymes, lipo and glycoproteins.



ME-CELLAS

#### Using Cellas Gel

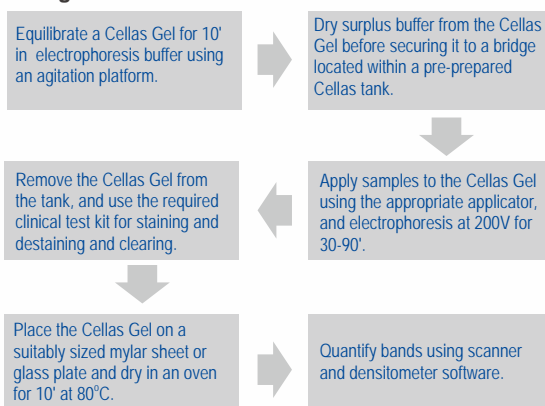

Applicators : Variety of rapid sample applicators are available for a selection of applications:

- Two specimen applicator for semi micro samples on strips 250mm wide.
- Four specimen applicator for semi micro samples on strips 570mm wide.
- Four specimen applicator for Haemoglobin samples on strips 570mm wide.
- Six specimen applicator for samples on strips 570mm wide.

#### Features

- Compact high resolution systems for Clinical Electrophoresis
- Can accommodate cellulose acetate strips up to 240x200mm
- Complete range of cellulose acetate gels and kits
- Range includes densitometer, scanner and software
- Ideal for Clinical Electrophoresis Tests

Kits: Kits are available for multiple tests on serum proteins, haemoglobin, urine proteins and for immunofixation.

Bridges: Bridges are available in variety of formats for cellulose acetate sheets of dimension and for arched and horizontal Helena types of gels.

#### Specification

Cat. No.	ME-CELLAS
Strip Dimension (WxL)	Approx. 9.5"x7.9" (240x200mm) max.
Dimension (WxL)	Approx. 11.8"x11.8" (300x300mm)

#### Ordering Information

Cat. No.	Product Description
ME-CELLAS	Horizontal unit for Cellulose Acetate Electrophoresis

#### Accessories

Cat. No.	Product Description
ME-GEL2.514250	25x140mm, CellasGEL 250 micron, standard thickness, 100/pack
ME-GEL2.514200	25x140mm, CellasGEL 200 micron, standard thickness, 100/pack
ME-GEL2.514190	25x140mm, CellasGEL 190 micron, high resolution, 100/pack
ME-GEL5.714500	57x140mm, CellasGEL 500 micron, high volume, 25/pack
ME-GEL5.714250	57x140mm, CellasGEL 250 micron, standard thickness, 25/pack
ME-GEL5.714200	57x140mm, CellasGEL 200 micron, standard thickness, 25/pack
ME-GEL5.714190	57x140mm, CellasGEL 190 micron, high resolution, 25/pack

ME-APPS22	Applicator, 1x2-specimen semi-micro, for CellasGEL strip size 25x140mm
ME-APPS4SP	Applicator Semi-micro 4 for 0.9ul volume applied/ 9mm – First type
ME-APPS4	Applicator Semi-micro 4 for 1.2ul volume applied/ 9mm – First type
ME-APPS6	Applicator Semi-micro 6 for 0.7ul volume applied/ 7mm – First type
ME-APPM8	Applicator Micro 8 for CellasGEL

ME-BDG8.5S	CSLBDG8.5S Bridge 85mm (standard size for CellasGEL kits) for CellasGEL strips 57x140mm or 25x140mm
ME-DENS	TurboScan software densitometer (excludes computer and scanner)
ME-SCAN	Flatbed scanner for TurboScan software

# Denaturing Gradient Electrophoresis

## MV20-WAVE-DGGE

The MV20-WAVE-DGGE is a complete system for DNA mutation analysis. It is fully equipped with temperature control unit, stirrer, and gradient mixer and casting accessories to perform specific mutation analysis applications. A powerful microprocessor controlled PID temperature control unit enables various mutation detection techniques to be undertaken between ambient temperature and 70°C, while the simple four screw design of the WAVE insert accelerates set up of denaturing PAGE gels. The flexibility provided by the modular design of the MV20-WAVE-DGGE and its wide range of accessories enables laboratories to switch quickly and easily between different mutation detection techniques, thereby maximizing throughput and screening efficiency. A maximum 96-sample throughput allows detection of as many mutations within a couple hours, alleviating many of the bottlenecks associated with screening for DNA mutations.



MV20-WAVE-DGGE



### Features

- Maximum 96-sample throughput
- Large format – 200x200mm glass plates
- Use with 100ml gradient mixer to make two 1mm parallel denaturing gradient gels
- Compatible with microplates and thermal cycler blocks
- Ideal for detection of single base changes and polymorphisms in genomic cloned and amplified DNA fragments

### Ordering Information

Cat. No.	Product Description
MV20-WAVE-DGGE-110/220	Complete denaturing gradient gel electrophoresis system, 200x200mm; includes: temperature control unit, cam casting base, glass plates with 1mm bonded spacers, 2x24-sample combs and gradient mixer, 110V / 220V
MV20-WAVE-DGGETC-110/220	MV20-WAVE-DGGE-110 temperature control unit, 110V / 220V
MGM-100	Gradient mixer, 100ml
<b>Recommended Accessories</b>	
MU-D01	Digital Peristaltic Pump, 110 / 220V~
MU-S16	Silicon tube I.D. 0.12 inch (3.1mm), 25ft
MP-510	Lively 500V Power Supply

### Specification

Cat. No.	MV20-WAVE-DGGE
<b>WAVE Electrophoresis Insert And Tank</b>	
Max. Number Of Gels	2 per run
Plate Dimension (WxH)	Approx. 7.9"x7.9" (200x200mm)
Active Gel Dimension (WxH)	Approx. 6.3"x6.9" (160x175mm)
Thicknesses	0.75, 1, 1.5 and 2mm
Max. Sample Capacity	96 samples; 48 per gel
Standard Combs	2x1mm 24-sample
Available Combs	1, 5, 10, 18 MC, 24, 36 MC, 48; as per MV20WAVE and Maxi units
Max. Buffer Volume	2.25gal (8.5L)
Dimension (WxLxH)	Approx. 15.9"x6.7"x1.7" (405x170x440mm)
Weight	Approx. 17.6lb (8kg)
<b>Temperature Control Unit</b>	
Temperature Control	PID
Operating Temperature Range	Ambient - 100°C
Working Temperature Range (DGGE)	45-70°C
Buffer Recirculation Mechanism	Stirring
Temperature Uniformity / Stability At 37°C	±0.05 / 0.02°C
Setting / Display Resolution	0.1°C
Safety	Fluid-level float switch; isolated; IEC 1010/CE
Stored Temperature Values	4
Heater Power At 230V/110VAC	1.4/1.3kW
Electrical Power At 230V/100VAC	1.5/1.4kW (50-60Hz)
<b>Recommended Power Supply MP-510</b>	
Rated Voltage	500V
Current	800mA / 500ml
Power	300 W / 150W
<b>Gradient Mixer</b>	
Total Volume	100ml
Volume Of Reservoir & Mixing Chambers	50ml
Internal Diameter Of Outlet Port	2mm



# Gradient Formers

## MGM series

Five different sizes of Gradient Former, 15, 25, 50, 100 and 500ml are available. The smaller sizes, 15ml and 25ml are ideal for the preparation of centrifugation gradient by using sucrose or cesium chloride solutions. The larger sizes, 50ml, 100ml, and 500ml are mainly used for the preparation of linear polyacrylamide gel gradients. The gradient formers are made from a single acrylic block, except for the 500ml gradient former, which is made from acrylic tubes. They all consist of two chambers, a reservoir and a mixing chamber, with an interconnecting valve. A second valve regulates the output flow from the mixing chamber, except MGM-500. A magnetic stirring bar is placed in the mixing chamber to maintain a constant gradient. All of the products have a flat base to be placed on a magnetic stirrer. They also have a support rod, which can be used to fix the gradient formers to a retort stand for extra stability.

### Ordering Information

Cat. No.	Product Description
MGM-15	For 15ml gradient former
MGM-25	For 25ml gradient former
MGM-50	For 50ml gradient former
MGM-100	For 100ml gradient former
MGM-500	For 500ml gradient former

### Features

- Low cost
- Simple construction
- Easy assembly
- Well gradient performance



MGM series



Simple construction

# Cool Cube

## MS-COOLCUBE

The Cool Cube is designed to help you store your precious samples safely on lab bench without worrying about the degradation caused by temperature increment. The Cool Cube maintains temperature at approximately 0 °C for up to four hours. Simply place the Cool Cube in a freezer overnight and it will be ready to use.

One side of the Cool Cube could be used for a convenient PCR workstation for 12 standard 1.5/2.0ml microtubes with one 96 well PCR plate, or with 12x0.2ml strips or 96x0.2ml tubes. The other side of the cube may be used to hold up to 36 standard 1.5/2.0ml microtubes.

### Specification

Cat. No.	MS-COOLCUBE
Temperature	4°C for up to 4 hours
Capacity	36x1.5ml
	96x0.2ml
	12x0.2ml PCR strips 1x96 well PCR plate
Dimension (WxLxH)	Approx. 5.6"x5.6"x2.5" (142x142x63.5mm)
Weight	2lb (900g)
Material	Durastar Polymer

### Features

- Maintains 0°C for up to 4 hours
- Holds both microtubes and a PCR plate
- Can be used as a PCR workstation

### Ordering Information

Cat. No.	Product Description
MS-COOLCUBE	Coolcube storage rack



MS-COOLCUBE

# Flatbed IEF System

## MIEF

The Flatbed IEF System has been designed to perform all flat bed IEF techniques, including wick-based electrophoresis with horizontal and hand-cast IEF gels, and focusing with IPG strips. The unit includes a large cooling platform which offers increased strip capacity and active gel area. Uniform cooling of the platform is achieved using a large ceramic plate that may be connected to any standard chiller via quick-fit connectors for enhanced gel or strip cooling. An optional rehydration tray is also available for overnight rehydration of up to twelve IPG strips before use.

### Features

- For IPG strip and IEF gel applications
- Large cooling platform area
- Pick-and-place easy to position electrodes
- Grid for accurate electrode alignment
- Rehydration tray also available

### Specification

Cat. No.	MIEF
Max. Strip Length	Approx. 9.4" (240mm)
Max. Gel Dimension	Approx. 10.2"x10.2" (260x260mm)
Dimension (WxLxH)	Approx. 21.7"x13.8"x3.9" (550x350x100mm)

### Ordering Information

Cat. No.	Product Description
MIEF	Flatbed IEF system for IEF strips and gels



MIEF

# Midi Gel Dryer

## MG series

The microprocessor of the Midi Gel Dryer controls temperature from ambient +5°C to 90°C with a timer from 0 to 9999 minutes to heat gels from the base plate while connected to a vacuum pump to remove the moisture and dry gels homogeneously. The surrounding groove design and sealing silicon rubber mask ensure optimal sealing when connecting to a vacuum pump.



2 digital LED displays



MG-2131



MG-3545

### Features

- Drying area (WxL): 310x210mm or 450x350mm
- Microprocessor for temperature control
- User temperature calibration
- Timer with alarm
- 2 digital LED displays

### Specification

Cat. No.	MG-2131	MG-3545
Drying Area (WxL)	12.2"x8.3" (310x210mm)	17.7"x13.8" (450x350mm)
Display	Two of 4 digital LED	
Control	Digital Microprocessor Controller	
Temperature Control Range	Ambient to 90°C	
Temperature Increment	0.1°C	
Temperature Calibration	Yes	
Timer	9999 (min)	
Operating Temperature	Ambient to 40°C	
Weight	Approx. 19.8lb (9.0kg)	Approx. 33lb (15.0kg)

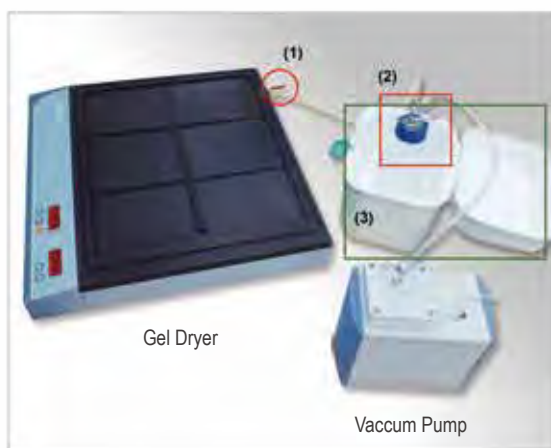

Gel Dryer

Vacuum Pump

1. Remember to turn the red valve on when start sucking from inlet port of vacuum pump.
2. Remember to prepare a vessel/bottle which has 2 ports for outlet and inlet to gather the fluid.
3. A container with some ice will help cooling down the temperature in the bottle. In addition, it also helps reducing the chemical odor.

### Ordering Information

Cat. No.	Product Description
MG-2131-110/220	Midi 210x310mm Gel Dryer
MG-3545-110/220	Midi 350x450mm Gel Dryer

### Accessories

Cat. No.	Product Description
MG-2131-MAT	Polythylene filter mat 210x310mm
MG-3545-MAT	Polythylene filter mat 350x450mm
MG-2131-SR	Silicon Rubber 270x370mm
MG-3545-SR	Silicon Rubber 410x530mm

\*All images are for reference only, actual products might differ from the pictures above.  
 \*Please visit our website at [www.majorsci.com](http://www.majorsci.com) for more product selection and detailed information.  
 \*Technical specification subject to change without notice.

# MS Pipette

## MSP series



MS Pipette is a reliable instrument that can perform accurate, contamination-free experiment with ease.

Based on the latest innovation in terms of ergonomics and comfort, the main body is designed for easy operation by either right or left hand, big or small hand. The new piston mechanism design requires low pipetting force and low maintenance frequency. The robust construction is fully autoclavable and chemical resistant, which provides user contamination-free and safe experiment environment.

On site calibration is easy to perform. In addition, MS Pipette is compatible with a majority of brands of tips on the market. With ISO certification, Major Science provides customers with the "Best Value" combination of quality, features, service and price. All accessory parts are available through Major Science service centers.



Pipette Stand, with additional alcohol sprayer



180° spray head

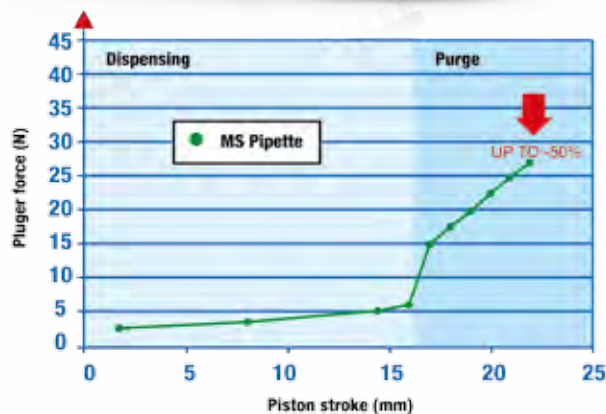

Conception of new seals and lighter springs and use of high quality lubricant:

- Reduce pipetting and purge forces by 50%
- Have an easy glide of the piston
- Maintain an adequate ratio (~1/3) between pipetting forces and purge forces to feel confident in results
- Maintain quality and robustness of our pipetting system.

- Light weight
- Soft spring system for extremely low pipetting forces
- Controlled volume setting to prevent accidental volume changes
- Different color coded push button for different volume
- Contoured shape: fits either small or large hands
- Large pushbutton, rounded and freely rotating
- Finger hook: takes the weight, for a more relaxed grip
- 3-position tip ejector button (left/right handed users)
- Easy on site calibration (calibration key included)
- High accuracy and precision
- A unique serial number
- UV resistance even under prolonged exposure
- Fully autoclavable (121°C/0.1MPa/20 min)



### Ordering Information

Cat. No	Description
MSP-2	MS pipette, variable volume 0.2~2µl
MSP-10	MS pipette, variable volume 1~10µl
MSP-20	MS pipette, variable volume 2~20µl
MSP-100	MS pipette, variable volume 10~100µl
MSP-200	MS pipette, variable volume 20~200µl
MSP-1000	MS pipette, variable volume 100~1000µl
MSP-5000	MS pipette, variable volume 500~5000µl
MSP-10000	MS pipette, variable volume 1000~10000µl
MSP-8X10	MS 8-ch pipette, variable volume 0.5~10µl
MSP-8X20	MS 8-ch pipette, variable volume 2~20µl
MSP-8X200	MS 8-ch pipette, variable volume 20~200µl
MSP-8X300	MS 8-ch pipette, variable volume 20~300µl
MSP-12X10	MS 12-ch pipette, variable volume 0.5~10µl
MSP-12X20	MS 12-ch pipette, variable volume 2~20µl
MSP-12X200	MS 12-ch pipette, variable volume 20~200µl
MSP-12X300	MS 12-ch pipette, variable volume 20~300µl
MSP-ST02	Pipette Stand, with additional alcohol sprayer





### Single Channel Models

Cat No.	Volume (µL)	SPECIFICATIONS				ISO 8655			
		Systematic Error		Random Error		Systematic Error		Random Error	
		(µL)	(%)	(µL)	(%)	(µL)	(%)	(µL)	(%)
MSP-2	0.2	±0.026	±13.2%	MSP-2	0.2	±0.026	±13.2%	MSP-2	0.2
	2	±0.033	±1.7%		2	±0.033	±1.7%		2
MSP-10	1	±0.028	±2.8%	MSP-10	1	±0.028	±2.8%	MSP-10	1
	10	±0.110	±1.1%		10	±0.110	±1.1%		10
MSP-20	2	±0.11	±5.5%	MSP-20	2	±0.11	±5.5%	MSP-20	2
	20	±0.20	±1.0%		20	±0.20	±1.0%		20
MSP-100	10	±0.39	±3.9%	MSP-100	10	±0.39	±3.9%	MSP-100	10
	100	±0.80	±0.8%		100	±0.80	±0.8%		100
MSP-200	20	±0.55	±2.8%	MSP-200	20	±0.55	±2.8%	MSP-200	20
	200	±1.60	±0.8%		200	±1.60	±0.8%		200
MSP-1000	100	±3.3	±3.3%	MSP-1000	100	±3.3	±3.3%	MSP-1000	100
	1000	±0.8	±8.0%		1000	±0.8	±8.0%		1000
MSP-5000	500	±13	±2.6%	MSP-5000	500	±13	±2.6%	MSP-5000	500
	5000	±33	±0.7%		5000	±33	±0.7%		5000
MSP-10000	1000	±33	±3.3%	MSP-10000	1000	±33	±3.3%	MSP-10000	1000
	10000	±60	±0.6%		10000	±60	±0.6%		10000

### Multichannel Models

MSP-8X10	0.5	±0.09	±17.6%	MSP-8X10	0.5	±0.09	±17.6%	MSP-8X10	0.5
MSP-8X20	2	±0.11	±5.5%	MSP-8X20	2	±0.11	±5.5%	MSP-8X20	2
MSP-8X200	20	±0.6	±2.8%	MSP-8X200	20	±0.6	±2.8%	MSP-8X200	20
MSP-8X300	20	±1.1	±3.7%	MSP-8X300	20	±1.1	±3.7%	MSP-8X300	20
MSP-12X10	10	±0.22	±2.2%	MSP-12X10	10	±0.22	±2.2%	MSP-12X10	10
MSP-12X20	20	±0.40	±2.0%	MSP-12X20	20	±0.40	±2.0%	MSP-12X20	20
MSP-12X200	200	±2.2	±1.1%	MSP-12X200	200	±2.2	±1.1%	MSP-12X200	200
MSP-12X300	300	±3.3	±1.1%	MSP-12X300	300	±3.3	±1.1%	MSP-12X300	300

Precise volume adjustment & light pipetting forces



**MS Pipette**

**SINGLE CHANNEL**  
is available in 8 models and covers the volume range from 0.2µL to 10mL

**MS Pipette**

**MULTI CHANNEL**  
is available in 8 models and covers the volume range from 0.5µL to 300µL.

## Amplification/PCR

Thermal Cycler, PCR Workstation

Major Science provides a reliable and promising PCR/amplification instrument line to suit your everyday polymerase chain reaction needs. From sanitary PCR station that protects the working area from cross-contamination to state-of-art high performance Thermal Cycler, this product range is perfect to use in any lab.

### Amplification/PCR

#### ▣ Thermal Cycler

51

Major Cyclers

#### ▣ PCR Workstation

52

UV Sterilization Cabinet

Mini UV Sterilization Cabinet



\*All images are for reference only, actual products might differ from the images.

\*Please visit our website at [www.majorsci.com](http://www.majorsci.com) for more product selection and detailed information.

\*Technical specification subject to change without notice.

# Major Cyclor CYCLER-25

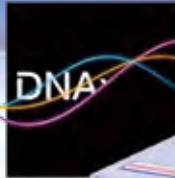

Major Cyclor is an automated instrument designed for application in hot start thermal cycling reactions with additional reverse transcription (RT) program function, it is simple and convenient to run one-step RT by combining the RT program with a stored amplification reaction. Another feature of Major Cyclor is the flexible program editing, which allows researchers to set up an amplification program containing different temperature ramping conditions within individual loops. Major Cyclor also offers the flexibility to create an advanced amplification program which could increase/decrease temperatures and hold time for an assigned step from cycle to cycle. The small size and competitive pricing make it suitable for a personal instrument ownership.

Self pressure  
adjusting  
heated lid

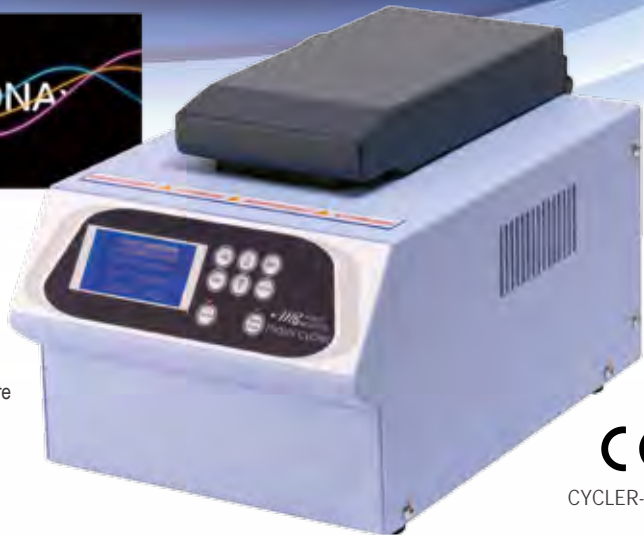

CE  
CYCLER-25

## Features

- Microprocessor control with digital performance
- Wide temperature control range and great temperature controlling performance
- LCD display
- Self pressure adjusting heating lid
- User friendly and powerful program performance
- RT program
- Link up to 5 loops for one program
- Up to 9 steps for each loop
- Up to 99 cycles for each loop

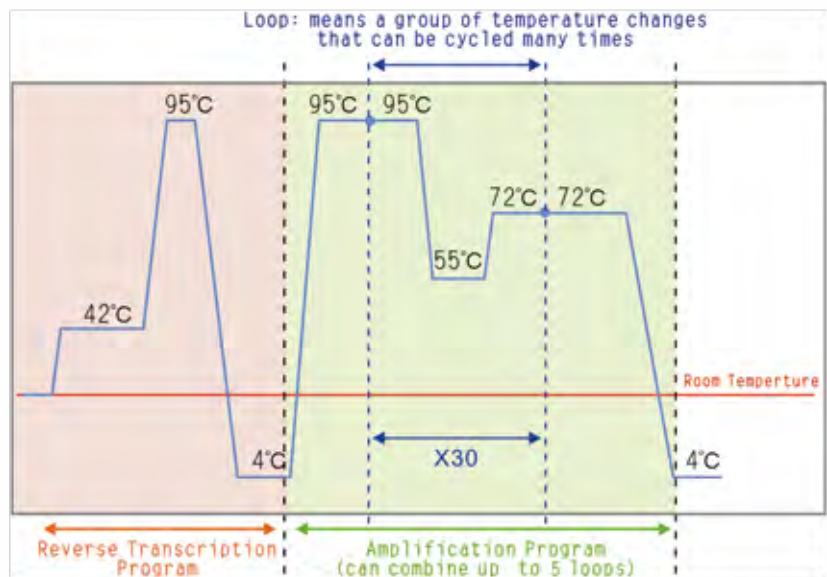

## Specifications

Cat. No.	CYCLER-25
Sample Capacity	25(5x5)x0.2ml tube
Temperature Control Range	4°C to 110°C
Lid Temperature Control Range	Ambient + 5°C to 110°C
Block Homogeneity	20°C to 72°C ≤ ± 0.3°C; 95°C: ≤ ± 0.4°C
Control Accuracy	± 0.2°C
Heating Rate	Approx. 3°C / s
Cooling Rate	Approx. 2°C / s
Display	2.6" LCD
Program	Reverse transcription program
	Link program: multi-loop available; up to 5
	Step per Loop: up to 9
	Cycle number: up to 99
	Program storage: up to 100
Increment And Decrement Time Per Step On Each Cycle	Yes
Rated Voltage	110V / 220V- selectable
Dimension (WxLxH)	Approx. 7.9"x12.6"x7.5" (200x320.5x190mm)
Weight	Approx. 18.9lb (8.6kg)

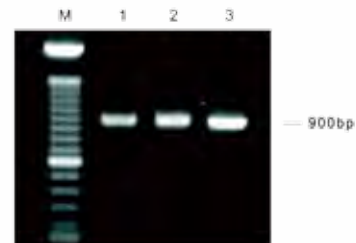

Reverse Transcription and amplification of 900bp Japanese Encephalitis Virus (JEV) envelope protein fragment from JEV RNA using Major Cyclor RT and amplification program

- M. DNA marker  
 1. 0.1µg RNA template  
 2. 0.5µg RNA template  
 3. 1.0µg RNA template

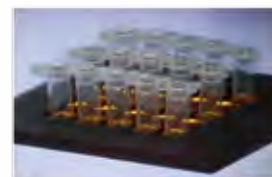

25(5x5)x0.2ml tube

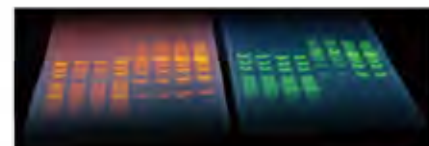

## Ordering Information

Cat. No.	Product Description
CYCLER-25	Major Cyclor, 25 wells



# UV Sterilization Cabinet

## MS-UVCAB

### For MS-UVCAB

The UV Sterilization Cabinet provide a convenient area for setting up PCR reactions in a nucleic acid free environment thus preventing PCR reaction contamination. Acting effectively as a low cost alternative to a clean room, the powerful UV light on the cabinets emits UV light to denature any nucleic acids in 5 to 30 minutes, making them inactive for amplification. The cabinet incorporates safety features to prevent user exposure to UV light.

The UV light have timer control and also provided with safety switches on the cabinets doors which turn off the UV light when opened.

The cabinets also act as an efficient shield of beta radioactive emissions and can therefore be safely used with isotopes such as <sup>32</sup>P.

White light within the system provides excellent visibility when working within the cabinets.

### Features

- Inactivates nucleic acids in 5 to 30 minutes
- Doors fitted with safety switches
- Complete with four powerful, timer controlled UV bulbs
- Efficient decontamination of the complete work surface
- Suitable for work with <sup>32</sup>P



MS-UVCAB

### Specification

Cat. No.	MS-UVCAB	MS-UVCABMINI
UV Light	4x15W	4x15W
White Light	15W	15W
Dimension (WxLxH)	Approx. 22"x16.5"x30.3" (560x420x770mm)	Approx. 22"x13.8"x20.1" (560x350x510mm)
Weight	Approx. 41.9lb (19Kg)	Approx. 26.5lb (12Kg)
Cabinet Material	Acrylic	Acrylic

### Ordering Information

Cat. No.	Product Description
MS-UVCAB-110/220	UV Sterilization Cabinet with timer, four UV light and white light, no tray, 110V / 220V
MS-UVCABMINI-110/220	Mini UV Sterilization Cabinet with timer, UV light and white light, no tray, 110V / 220V
MS-TL4	Liners - 68x54cm, PK/25 (FOR CABINET)
MS-TW4	General Purpose Tray (white) - 680x540mm
MS-TY4	Radiation Hazard Tray (yellow) - 680x540mm
MS-UVTUBE	Replacement UV Tube for cabinets
MS-WHITETUBE	Replacement White Light Tube for cabinets



MS-TY4



MS-TW4

# Mini UV Sterilization Cabinet

## MS-UVCABMINI

### For MS-UVCABMINI

The Mini UV Sterilization Cabinet has all the benefits from the UV Sterilization Cabinet but with smaller in size which is the perfect solution for laboratories constrained by space and budget. A reduced height and footprint allows the Mini UV Cabinet to fit snugly and conveniently to any small areas within the lab.

### Features

- Inactivates nucleic acids in 5 to 30 minutes
- Doors fitted with safety switches
- Complete with four powerful, timer controlled UV bulbs
- Efficient decontamination of the complete work surface
- Suitable for work with <sup>32</sup>P



MS-UVCABMINI



Timer for convenient operation



Easy side access



## Gel Documentation System

Major Science offers a wide range of Gel Documentation System specifically designed to fit researchers' specifications and budgets. Gel Documentation System are offered for a wide range of applications depending on the system and camera configurations. This product line also includes UV Transilluminators and UV / Blue light transilluminators for all your imaging needs. All products feature user-friendly operation, compact sizing and outstanding functions.

More blue light technology instruments are introduced to the category of blue light, [Page 66-73](#)

### Gel Documentation System

#### ▣ Imaging System

54-61

SmartView Pro Imager  
SmartView Pro Imager, CCD / CMOS  
SmartView Simple Imager System  
Compact Digimage System / Digimage System

#### ▣ Transilluminator

62-65

SmartView Transilluminator  
UV Transilluminator



\*All images are for reference only, actual products might differ from the images.  
\*Please visit our website at [www.majorsci.com](http://www.majorsci.com) for more product selection and detailed information.  
\*Technical specification subject to change without notice.



2.0 MP CCD Camera

# SmartView Pro Imager

UVCI-2300 / UVCI-2400



MS UVCI-2300/2400, the truly standalone Gel Imaging System, delivers incredible image and sharpness with power of the exceptional close-up monochrome 2.0 mega-pixel CCD camera, and get you ready for beautifully discriminable DNA/Protein gel images in the spaciouly intuitive 10.4" interface with color touch-screen. Our innovative systems are expandable with white and blue light plates coupled with versatility of camera filters, no matter it's an EtBr or EtBr-free operations, simply tab to view. Many post-imaging features like drawer-type platform and UV protection shield are added to your convenience for gel excision.



UVCI-2300 / UVCI-2400



Control Interface



System setup



Default setting

### Features

- Standalone gel doc system with high-quality monochrome CCD
- Exchangeable emission Filters provide for instant visualization
- Intuitive 10.4" interface with color touch-screen
- Zoom-able lens for proper picture size
- Movable platform for gel excision with UV-protection shield
- Automatic UV shut off mechanism (UVCI-2300 only)
- Optional trans white light and blue light plates (UVCI-2300 only)
- Exclusively designed for EtBr-free operation gel doc system (UVCI-2400 only)
- Optional trans white light plates for UVCI-2400



UV light protection warning



Batch file management



Blue light plate (UVCI-2300)

White light plate



White Light Plate (Flip type)

Blue Light Plate (Flip type)

UV Transilluminator (Drawer type)

UVCI-2300





UVCI-2300-EB



UVCI-2300-SG



UVCI-2300-F4



UVCI-2313



UVCI-2314

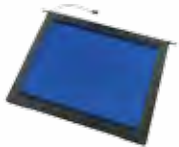

UVCI-2300-BL



UVCI-2300-WL



MJC-8-STYLUS-00000



CI-CL55+1

## Specifications

Model	SmartView Pro 2300	SmartView Pro 2400
Cat. No.	UVCI-2300	UVCI-2400
Camera	1/1.8" interline UXGA monochrome progressive 2.0MP CCD	
Pixels Size	4.4µm x 4.4µm	
Lens (Camera)	F1.2, 12.5 – 75mm (with one +1 close-up lens), 6X zoom lens, manual	
Camera Video Output	12bit	
Filter (Camera) *Ordered Separately	Optical EtBr Filter / Optical SYBR Green Filter / Orange Amber Filter	Orange Amber Filter
Image Storage	Built-in 14GB Memory (3000 tiff images storage) and USB flash	
Cabinet	Pull out, sliding transilluminator	
Field Of View (WxL)	Approx. 10.2"x8.3" (260x210mm)	
Dimension (WxLxH)	Approx. 16.1"x15.9"x36" (410x405x915mm)	
Weight	Approx. 62.8lbs. (28.5kg)	Approx. 56lbs. (25.4kg)
Display	10.4" color touch screen, 800x600	
Viewing Window	Built-in UV viewing window	Built-in blue light viewing window
Window Filter	Amber Filter embedded in viewing window (580nm)	
Light Source	Built-in drawer type UV Transilluminator 312(302)nm	Built-in drawer type blue light transilluminator 470nm
	Epi white light	
Optional Accessory	White Light Plate (power built-in)	
	Blue light plate (power built-in) 470nm	N/A
Saved Image	Max. 16bit	
Grayscale	12bit, 0-4095 gray levels	
Safety	CE	
Rated Voltage	100-240V~, 50/60Hz	

## Ordering Information

Cat. No.	Product Description
UVCI-2300	SmartView Pro 2300 Imager System, UV light version
UVCI-2400	SmartView Pro 2400 Imager System, Blue light version

\* All filters have to be ordered separately.

## Accessories

Cat. No.	Product Description
UVCI-2300-EB	SmartView EtBr Filter, 610nm (for UV)
UVCI-2300-SG	SmartView SYBR Green Filter, 520nm (for UV)
UVCI-2300-F4	SmartView Amber Filter, 580nm (for blue light)
UVCI-2313	SmartView Pro UV Protection Shield, for 2300 series
UVCI-2314	SmartView Pro Lens Filter Stand, can hold up to 4 lens filters, for 2300 & 2400 series
UVCI-2300-BL	Blue Light Plate for SmartView Pro 2300 series
UVCI-2300-WL	White Light Plate 210x260mm for SmartView Pro 2300 & 2400 series
MJC-8-STYLUS-00000	Stylus Pen
CI-CL55+1	55mm Close up lens +1 for CCD Image System
MBE-IMG-SW	MS 1D Analysis Software
DI-TOTALLAB	Totallab 1D Gel Analysis Software



Viewing via window



Viewing via screen



Viewing window  
(Amber filter, 580nm)

# SmartView Pro Imager, CCD SmartView Pro Imager, CMOS



UVCI-2100 series  
UVCI-1100 series

The SmartView Pro 2100 is simply the upgraded version of UVCI-1100. The SmartView Pro 2100 offers all same great features except the 2.0 megapixel CCD camera to provide image with sharper sensitivity, and less exposure time. All the accessories are shared between 1000 and 2000 so it's easy and simple to use. All great features such as pre-focused lens, safety UV door and 1D analysis software are all included as standard. Enjoy the most compact CCD imaging system for all of your laboratory work.

The SmartView Pro 1100 provides the basic feature and standard operation.

2.0 MP CCD Camera



UVCI-2100



\*PC is not included\*

UVCI-1100

5.0 MP Monochrome Camera

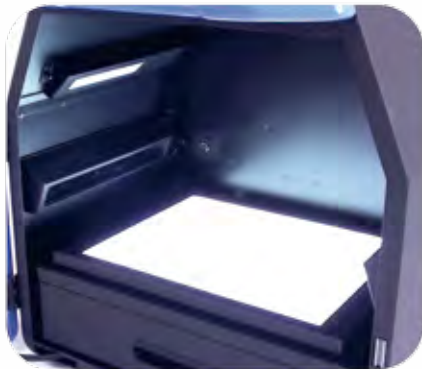

White Light Plate for protein analysis

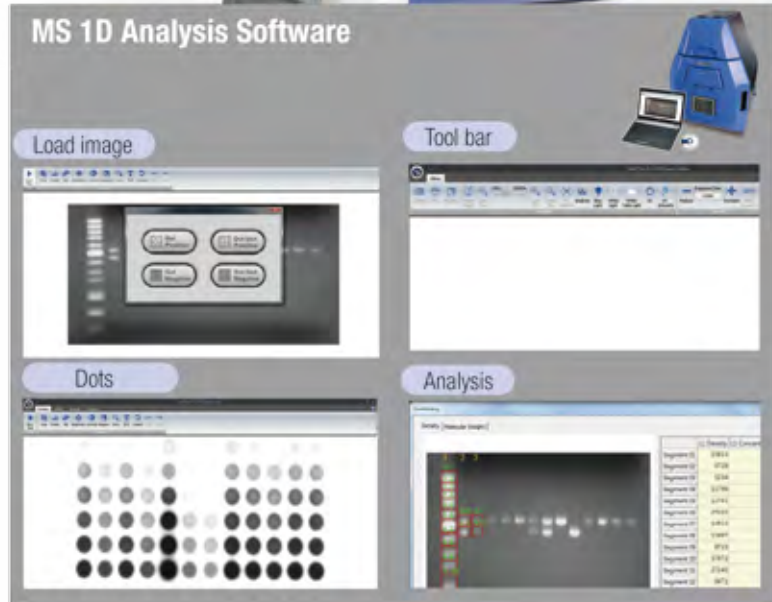

UV protection shield is easily installed by magnetic design



UV Protection Shield



Easily gel cutting design with UV



Lens filter stand up to 4 Filters



Easily placed by magnet near camera



Viewing window (Amber filter, 560nm)

**Features**

- High resolution CCD camera (UVCI-2100)
- High resolution 5.0 megapixel monochrome camera (UVCI-1100)
- PC integration with real time image
- Capture/Analysis software included
- Pull out UV Transilluminator for easy gel cutting
- Easy installation, ready to use right out of the box
- Pre-focused lens allow one touch image capture
- Variety of optional accessories available
- UV safety cut-off switch when door is open
- CE and FCC certification

## Specifications

Model	SmartView Pro 2100	SmartView Pro 1100
Cat. No.	UVCI-2100	UVCI-1100
UV Light	Built-in drawer type UV Transilluminator 312(302)nm	
Camera	1/1.8" interline UXGA monochrome progressive 2.0MP CCD	1/2.5" 5M Pixel Monochrome sensor
Pixels Size	4.4µm x 4.4µm	2.2µm x 2.2µm
Lens (Camera)	6mm, F1.2	
Camera Video Output	12-bit	
Filter (Camera) *Ordered separately	Optical EtBr Filter / Optical SYBR Green Filter / Yellow Amber Filter / Orange Amber Filter	
Image Storage	PC	
Software Support	Window 10 / 8 / 7 (64bit & 32bit) / XP / Vista	
Cabinet	Pull out, sliding transilluminator	
Field Of View (WxL)	Approx. 10.2"x8.3" (260x210mm)	
Dimension (WxLxH)	Approx. 16.1"x15.9"x22.4" (410x405x570mm)	
Weight	Approx. 54lbs. (24.5kg)	
Display	LED indicator light	
Viewing Window	Built-in UV viewing window	
Window Filter	Built-in Viewing Window Amber Filter 560nm	
Light	White light (standard)	
Optional Accessory	White Light Plate (power built-in)	
	Blue light (power built-in) 470nm	
Safety	CE, FCC	
PC Connection	USB port	
1 D Analysis Software	Cat. No. MBE-IMG-SW included	
Saved Image	BMP/JPEG/PNG/TIFF, 8 bit; PNG/TIFF, 16 bit	
Rated Voltage	100-240V~, 50/60Hz, 2A	

\* iPad and PC not included.

## Ordering Information

Cat. No.	Product Description
UVCI-2100	SmartView Pro 2100 Imager System, standard version
UVCI-2101	SmartView Pro 2100 Imager System, standard version, high UV performance
UVCI-1100	SmartView Pro 1100 Imager System, standard version
UVCI-1101	SmartView Pro 1100 Imager System, standard version, high UV performance

\* All filters have to be ordered separately.

## Accessories

Cat. No.	Product Description
UVCI-1000-WL	White Light Plate for SmartView Pro Imager System, 1100 & 2100 series
UVCI-1000-BL	Blue Light Module for SmartView Pro Imager System, 1100 & 2100 series
UVCI-1000-EB	SmartView EtBr Filter, 610nm (for UV)
UVCI-1000-SG	SmartView SYBR Green Filter, 520nm (for UV)
UVCI-1000-F1	Viewing window Amber filter, 560nm for SmartView Pro Imager System, 1100 & 2100 series
MBE-IMG-F3	SmartView Amber Filter 560nm
MBE-IMG-F4	SmartView Amber Filter 580nm
UVCI-1003	SmartView Pro UV Protection Shield, for 1100 & 2100 series
UVCI-1004	SmartView Pro Lens Filter Stand, can hold up to 4 lens filters, for 1100 & 2100 series
MBE-G-Y1	Amber Filter Viewing Glasses, 560 nm (optional)
MBE-IMG-SW	MS 1D Analysis Software
DI-TOTALLAB	Totallab 1D Gel Analysis Software

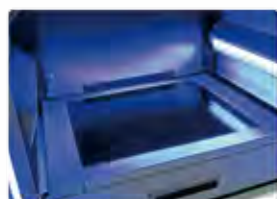

Epi-blue light for optional light source



Optional blue light device



Sliding transilluminator



# SmartView Simple Imager System

## MUV-IMG-CA

Major Science offers SmartView Simple Imager System for your UV or blue light Transilluminator. This unit is designed for extremely light in weight and compact in size.

For any lab with limited budget and lab space, the SmartView Simple Imager System is definitely your top choice of selection. It is compatible with most of the transilluminators on the market. (for any maximum viewing size less than 260x210mm)

Digital camera model gives you great resolution of 18 megapixels, and provides you a PC-free operation environment with high mobility.

CE



MUV-IMG-CA



DI-EB49



DI-SG49



DI-AM49

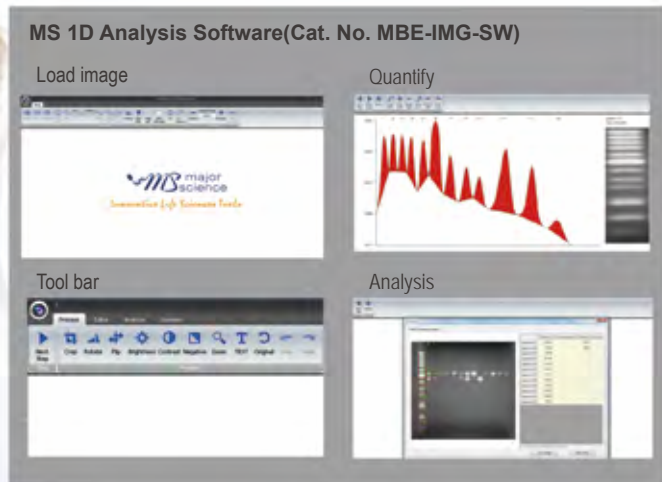

MS 1D Analysis Software(Cat. No. MBE-IMG-SW)

Load image



Quantify

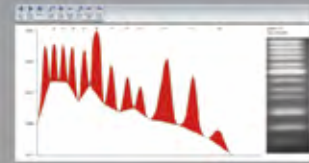

Tool bar



Analysis

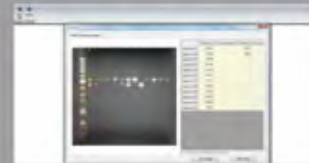

### Features

- Extremely light weight and compact in size
- 18 megapixel digital camera
- Can be operated PC free
- Optical filters available upon ordering (EtBr, SYBR, and 580nm Amber filter)



Wi-Fi function

\*PC is not included\*

## Specifications

Camera spec.	
Camera Type	18.0MP digital camera, Wi-Fi function
Effective Pixels	Approx. 18.0 Megapixels
Sensor	CMOS sensor (supporting Hybrid CMOS AF II)
Max. Aperture	f/3.5-6.3 (IS STM Lens)
Shutter Speed	1/4000 - 30sec. (available range varies by shooting mode)
Storage Media	SD memory card, Wi-Fi to PC, Smartphone or Tablet
Computer Interface	USB 2.0 Hi-speed (mini-B jack) or WiFi connection
Video Out	Full HD / HD / NTSC / PAL
Image Resolution	5184x3456
Lens	35mm film equivalent focal length, approx. 1.6 times the lens focal length
File Format	Designed rule for Camera File system 2.0
Data Type	JPEG, RAW(14-bit, Canon original), RAW+JPEG simultaneous recording possible
Filter (For Camera, Optional)	"EtBr filter / SYBR Green filter / Amber Filter *ordered separately"
Darkroom	
Dimension (WxLxH)	Approx. 9.3"x12.5"x16.5" (236x317x420mm)
Material	Acrylonitrile Butadiene Styrene (ABS)
Weight	Approx. 3.1lbs. (1.4Kg)
Camera Adapter Material	Aluminum

\* iPad and PC not included.

## Ordering Information

Cat. No.	Description
MUV-IMG-CA	SmartView Simple 310 Imager system, with 18.0 MP digital camera
MUV-IMG-CA-01	SmartView 310 holder kit, includes hood and camera adapter only

\* All filters have to be ordered separately.

## Bundle Package

Cat. No.	Description
MUV21-CP-02	Complete package of MUV21-312 Transilluminator and SmartView Simple 310 Imager System (MUV-IMG-CA)
MUV26-CP-02	Complete package of MUV26-312 Transilluminator and SmartView Simple 310 Imager System (MUV-IMG-CA)
MUVB-111-CP-02	Complete package of SmartView 111 Transilluminator and SmartView Simple 310 Imager System (MUV-IMG-CA)
MUVB-114-CP-02	Complete package of SmartView 114 Transilluminator and SmartView Simple 310 Imager System (MUV-IMG-CA)

## Accessories

Cat. No.	Product Description
MBE-IMG-SW	MS 1D Analysis Software
DI-TOTALLAB	Totallab 1D Gel Analysis Software
Filter (for camera) *ordered separately	
DI-EB49	EtBr filter, 49mm
DI-SG49	SYBR Green filter, 49mm
DI-AM49	Amber filter, 49mm



MUV-IMG-CA



MUV-IMG-CA-01



MUV21-CP-02 /  
MUV26-CP-02



MUVB-111-CP-02  
MUVB-114-CP-02

# Compact Digimage System Digimage System

## UVDI series DI series

### For UVDI series

The Compact Digimage System is a complete and compact gel documentation system with a digital control panel. The system uses a digital camera for image capture. The system is equipped with a built-in UV Transilluminator and a large 8" TFT colorful screen for gel observation. Its side access design provides a safe and convenient way for the user to recover agarose gel bands. For a low budget and limited space, the Compact Digimage System can be operated without a computer. A variety of images can captured including: agarose and other fluorescent gels, colorimetric gels, autoradiography film, and blotting membrane. A safety switch is equipped to turn off the UV Transilluminator automatically when the front door is opened. Files can be saved in a variety of formats, including RAW format, for transfer to a computer for storage and analysis.

### For DI series

The Digimage System is a simple, compact gel documentation system with a rear digital control panel. It contains the Canon EOS M10, a digital camera with a superb resolution of 18 megapixels. The image is viewed from a large 8" TFT colorful screen with monitor purpose only. For a lab with limited space and low budget requirements, the Digimage System is definitely your top choice since it's computer-free operation. A variety of images can be captured including: agarose and other fluorescent gels, colorimetric gels, auto radiography film, and blotting membrane. A safety switch is equipped to turn off the UV Transilluminator automatically when the front door is opened. Files can be saved in a variety of formats, including RAW format, for transfer to a computer for storage and analysis.



Viewing window

Convenient access

Digital control panel

UVDI-CB series

UVDI series is offered as a complete system for the user to perform image capture, including:

- 1 x Compact Digimage System chamber
- 1 x Digital camera
- 1 x DC coupler
- 1 x 8" color TFT screen
- 1 x Memory card
- 1 x Memory card reader
- 1 x Built-in UV transilluminator



Wi-Fi function  
\*PC is not included\*

### Features

- 18 megapixel digital camera
- High resolution 8" TFT screen
- Digital control panel
- Compact chamber and lightweight
- Can be operated PC free
- Inner white light LED at two sides
- Safety door switch
- Optional gel analysis software package available
- Universal rated voltage: 100-240V~
- Built-in UV Transilluminator (UVDI)



High resolution 8" TFT screen



DI-01

MBE-200A

DI-01 is offered as a complete system for the user to perform image capture, including:

- |                          |                         |
|--------------------------|-------------------------|
| 1 x Digimage System hood | 1 x Digital camera      |
| 1 x DC coupler           | 1 x 8" color TFT screen |
| 1 x Memory card          | 1 x Memory card reader  |



## Specifications

UV Transilluminator (For UVDI)	
Wavelength	254 / 312 (302) / 365nm
Filter Size	Approx. 8.3"x8.3" (210x210mm)
Light Source	6 tubes, 8 watt/tube
Filter	Long life filter
Intensity Switch	High (100%) / Low (70%) Intensity switch
UVDI Darkroom	
Multi-power Source	For camera, inner white LED, TFT monitor
Inner White Light	2 white LED, 3 watt/LED
Safety Device	Safety door switch
Dimension (WxLxH)	Approx. 13.2"x21.3"x18.5" (335x540x470mm)
Material	Painted metal
Rated Voltage	110V - 220V~
Weight	Approx. 44lb (20kg)
Camera Adapter Material	Aluminum

DI-01 Spec.	
Multi-Power Source	For camera, Inner light lamp, TFT monitor
Inner White Light	2 white LED, 3 watt/LED
Safety Device	Safety door switch
Dimension (WxLxH)	11.4"x13.3"x15.9" (290x339x403mm)
Material	Painted metal
Rated Voltage	110/220V~, 50/60Hz, 1.6A
Weight	Approx. 12.9lb (5.8kg)
Camera Adapter	Aluminum
DI Darkroom	
Dimension (WxLxH)	11.4"x13.3"x15.7" (290x339x398mm)
Weight	Approx. 11.9lb (5.4kg)

Camera Spec.	
Camera Type	18.0MP digital camera, Wi-Fi function
Effective Pixels	Approx. 18.0 Megapixels
Sensor	CMOS sensor (supporting Hybrid CMOS AF II)
Max. Aperture	f/3.5-6.3 (IS STM Lens)
Shutter Speed	1/4000 - 30sec. (available range varies by shooting mode)
Storage Media	SD memory card, Wi-Fi to PC, Smartphone or Tablet
Computer Interface	USB 2.0 Hi-speed (mini-B jack) or WiFi connection
Video Out	Full HD / HD / NTSC / PAL
Image Resolution	5184x3456
Lens	35mm film equivalent focal length, approx. 1.6 times the lens focal length
File Format	Designed rule for Camera File system 2.0
Data Type	JPEG, RAW(14-bit, Canon original), RAW+JPEG simultaneous recording possible
Filter (For Camera, Optional)	"EtBr filter / SYBR Green filter / Amber Filter *ordered separately"
Monitor	
Type	8" TFT LCD Monitor
Resolution	1024x600 pixels
Brightness	300cd / m2
Constant Ratio	700:1
Display Mode	NTSC / PAL auto switch

## Ordering Information

Cat. No.	Description
UVDI-254	Compact Digimage System with 18.0 MP digital camera and built-in 254 nm UV Transilluminator
UVDI-312	Compact Digimage System with 18.0 MP digital camera and built-in 312 (302) nm UV Transilluminator
UVDI-365	Compact Digimage System with 18.0 MP digital camera and built-in 365 nm UV Transilluminator
UVDI-254/365	Compact Digimage System with 18.0 MP digital camera and built-in 254 & 365 nm UV Transilluminator
UVDI-254/312	Compact Digimage System with 18.0 MP digital camera and built-in 254 & 312(302) nm UV Transilluminator
UVDI-CB-254	Compact Digimage System with built-in 254 nm UV Transilluminator only, digital camera not included
UVDI-CB-312	Compact Digimage System with built-in 312 (302) nm UV Transilluminator, digital camera not included
UVDI-CB-365	Compact Digimage System with built-in 365 nm UV Transilluminator, digital camera not included
UVDI-CB-254/365	Compact Digimage System with built-in 254 & 365 nm UV Transilluminator, digital camera not included
UVDI-CB-254/312	Compact Digimage System with built-in 254 & 312 (302) nm UV Transilluminator, digital camera not included
DI-01	Digimage System with 18.0 megapixels digital camera
DI-HD	Digimage System without digital camera

## Bundle Package

Cat. No.	Description
MUV21-CP-01	Complete package of MUV21-312 Transilluminator and Digimage System (DI-01)
MUV26-CP-01	Complete package of MUV26-312 Transilluminator and Digimage System (DI-01)
MUVB-111-CP-01	Complete package of SmartView 111 Transilluminator and Digimage System (DI-01)
MUVB-114-CP-01	Complete package of SmartView 114 Transilluminator and Digimage System (DI-01)

## Accessories

Cat. No.	Description
MBE-IMG-SW	MS 1D Analysis Software
DI-TOTALLAB	Totallab 1D Gel Analysis Software
DI-DR-E12	DC coupler
DI-WLA3-110/220	White Light Table 297x400mm (110/220V)
DI-WLA4-110/220	White Light Table 210x297mm (110/220V)
DI-WLA6-110/220	White Light Table 105x150mm (110/220V)
Filter (for camera) *ordered separately	
DI-EB49	EtBr filter, 49mm
DI-SG49	SYBR Green filter, 49mm
DI-AM49	Amber filter, 49mm



MUV21-CP-01/  
MUV26-CP-01



MUVB-111-CP-01  
MUVB-114-CP-01



DI-DR-E12



DI-WLA3 (297x400mm)  
DI-WLA4 (210x297mm)  
DI-WLA6 (105x150mm)



DI-EB49



DI-SG49



DI-AM49

# SmartView Transilluminator

## MUVB series

SmartView Transilluminator is the next generation of the illuminator for your lab. Combining the blue light and UV light, this equipment allows you to work either using blue light or UV light with your samples.

The Epi-Blue light proportionally emits your sample to give excellent fluorescence for you to view the nucleic acid bands. As the single or dual wavelength UV light allows you to induce stronger signals.

Moreover, since blue light is within visible light spectrum, it simply provides just enough energy to induce the signals without endangering operator safety.

In addition, this two-in-one system provides you additional convenience to work on any of your sample with UV light with or blue light simultaneously without moving your gel back and forth. SmartView Transilluminator is the ultimate source for any of your lab practice.

### Features

- Built-in blue light LED module with UV light
- Single or dual wavelength models available for different application purposes
- Adjustable UV protection cover for better viewing angle efficiency
- Industrial leading long life UV Filter
- Fast start up without flickering to instantaneously illuminate tubes
- High/Low intensity switch to minimize DNA degradation
- High efficiency reflector provides optimum use of UV light



MUVB  
FC CE

### Dye Application Guide

Cat. No.	UV Light	Blue Light
Major Blue	√	√√
SYBR® Green I (DNA)	√	√√
SYBR® Green II (RNA)	√	√√
SYBR® Gold	√	√√
Midori Green Direct	√	√√
Hydra Green™ Safe DNA Dye	√	√√
HD Green™ DNA Stain	√	√√
Novel Juice	√	√√
SafeView DNA Stain	√√	√
SYBR® Safe	√	√
Midori Green	√	√
Midori Green Advanced	√	√
Serva DNA Stain Clear G	√√	√
GelGreen™	√	√
GelRed™	√√	
Ethidium Bromide	√√	
HealthView™	√√	

√√ Excellent

√ Good



Built-in blue LED module provides flexibility in DNA stain selection



UV light applied



Blue light applied



Removable amber Filter

## Specifications

Model	SmartView
Filter Size (WxL)	Approx. 8.3"x8.3" (210x210mm)
Intensity Switch	High (100%) / Low (70%) intensity switch for single wavelength model
Fast Response	High quality starter to light up the tubes instantaneously and cause no blinking
Blue Light Source	1W x 18 lamps
UV Resistance Plastic Cover (WxL)	Approx. 8.9"x10.2" (225x260mm) (Transparent)
Blue Light Resistance Plastic Cover (WxL)	Approx. 8.9"x10.2" (225x260mm) (Orange)
Dimension (WxLxH)	Approx. 13.4"x11.3"x6.9" (340x286x176mm)
Rated Voltage	100-230V~, 50/60Hz, 2A
Weight	Approx. 24.7lb (11.2kg)

Model	Cat. No.	Type	Wavelength	UV Light Source (1tube / 8W)
SmartView 111	MUVB-111	Single	312(302)nm	5 tubes
SmartView 112	MUVB-112	Single	254nm	5 tubes
SmartView 113	MUVB-113	Single	365nm	5 tubes
SmartView 114	MUVB-114	Single	312(302)nm (high performance)	5 tubes
SmartView 121	MUVB-121	Dual	254nm / 312(302)nm	4 tubes / 5 tubes
SmartView 122	MUVB-122	Dual	254nm / 365nm	5 tubes / 4 tubes
SmartView 123	MUVB-123	Dual	254nm / 312(302)nm (high performance)	4 tubes / 5 tubes

## Ordering Information

Cat. No.	Product Description
MUVB-111	SmartView 111 Transilluminator with blue light and built-in UV, single wavelength 312(302)nm
MUVB-112	SmartView 112 Transilluminator with blue light and built-in UV, single wavelength 254 nm
MUVB-113	SmartView 113 Transilluminator with blue light and built-in UV, single wavelength 365 nm
MUVB-114	SmartView 114 Transilluminator with blue light and built-in UV, single wavelength 312(302) nm, high performance
MUVB-121	SmartView 121 Transilluminator with blue light and built-in UV, dual wavelength 254/312(302)nm
MUVB-122	SmartView 122 Transilluminator with blue light and built-in UV, dual wavelength 254/365nm
MUVB-123	SmartView 123 Transilluminator with blue light and built-in UV, dual wavelength 254/312 (302)nm, high performance

\* For different single wavelength models, please consult with your regional manager.

\* All filters have to be ordered separately.

## Bundle Packages

Cat. No.	Product Description
MUVB-111-CP-01	Complete package of SmartView 111 Transilluminator and Digimage System (DI-01)
MUVB-111-CP-02	Complete package of SmartView 111 Transilluminator and SmartView Simple 310 Imager System (MUV-IMG-CA)
MUVB-114-CP-01	Complete package of SmartView 114 Transilluminator and Digimage System (DI-01)
MUVB-114-CP-02	Complete package of SmartView 114 Transilluminator and SmartView Simple 310 Imager System (MUV-IMG-CA)

## Accessories

Cat. No.	Product Description
MBE-G-Y1	Amber Filter Viewing Glasses, 560 nm (optional)



MBE-G-Y1



MUVB-111-CP-01  
MUVB-114-CP-01



MUVB-111-CP-02  
MUVB-114-CP-02



# UV Transilluminator

## MUV series

The bench-top UV Transilluminator series offers the researcher uniform and intense sources of ultraviolet light (radiation) with a compact footprint. Their special design emits either one or dual intensity excitation UV wavelengths for back-illumination of transparent fluorescent materials. 254nm, 312 (302)nm, 365nm, 254 & 365nm, and 254 & 312 (302)nm modes are available for different applications. There are two choices of filter size viewing dimensions, 260x210mm and 210x210mm for different user requirements. The 365nm mode is offered for easily viewing gels under long wave for extended periods of time avoiding photo nicking damage. The 254nm mode is used to irradiate samples. The 312 (302)nm mode is suggested for general gel operating. The single wavelength modes have a high intensity / low intensity switch equipped. All bench-top transilluminator modes are compact, lightweight and economical.

A high performance model, 312 (302)nm UV Transilluminator with a strong lighting and longer life time tubes, was introduced for the requirement.



FC CE



Adjustable UV protection cover



MUV-21 series



MUV-26 series

### Features

- 254nm or 312 (302)nm or 365nm or 254/365nm or 254/312 (302)nm modes available
- 260x210mm or 210x210mm view dimension
- High intensity / low intensity switch for single wavelength model
- Adjustable UV protection cover for better viewing angle efficiency
- High performance models available
- Long life time filter

## Specification

Model	MUV26 series	MUV21 series
Wavelength	254 / 312 (302) / 365nm	
Filter Size	Approx. 10.2"x8.3" (260x210mm)	Approx. 8.3"x8.3" (210x210mm)
Light Source	6 tubes, 8W/tube	
Filter	Long life filter	
	High efficiency reflector	
Intensity Switch	High (100%)/Low (70%) intensity switch for single wavelength mode	
Fast Start Up	High quality starter to simultaneously illuminate tubes when switched on and no blink	
UV Resistant Plastic Cover (WxL)	Approx. 13"x9.8" (330x250mm)	
Dimension (WxLxH)	Approx. 13.4"x11.6"x3.9" (340x295x100mm)	
Weight	Approx. 16.5lb (7.5kg)	
Rated Voltage	110V/220V~	

## Ordering Information

Cat. No.	Product Description
MUV21-254	210x210mm Transilluminator for 254nm
MUV21-312	210x210mm Transilluminator for 312 (302)nm
MUV21-312H	210x210mm Transilluminator for 312 (302)nm, high performance
MUV21-365	210x210mm Transilluminator for 365nm
MUV21-254/365	210x210mm Transilluminator for 254 and 365nm
MUV21-254/312	210x210mm Transilluminator for 254 and 312 (302)nm
MUV21-254/312H	210x210mm Transilluminator for 254 and 312 (302)nm, high performance
MUV26-254	260x210mm Transilluminator for 254nm
MUV26-312	260x210mm Transilluminator for 312 (302)nm
MUV26-312H	260x210mm Transilluminator for 312 (302)nm, high performance
MUV26-365	260x210mm Transilluminator for 365nm
MUV26-254/365	260x210mm Transilluminator for 254 and 365nm
MUV26-254/312	260x210mm Transilluminator for 254 and 312 (302)nm
MUV26-254/312H	260x210mm Transilluminator for 254 and 312 (302)nm, high performance

## Bundle Packages

Cat. No.	Product Description
MUV21-CP-01	Complete package of MUV21-312 Transilluminator and Digimage System (DI-01)
MUV21-CP-02	Complete package of MUV21-312 Transilluminator and SmartView simple 310 Imager System (MUV-IMG-CA)
MUV26-CP-01	Complete package of MUV26-312 Transilluminator and Digimage System (DI-01)
MUV26-CP-02	Complete package of MUV26-312 Transilluminator and SmartView simple 310 Imager System (MUV-IMG-CA)

## Accessories

Cat. No.	Product Description
MUV-T254	8W 254nm UV lamp
MUV-T312	8W 312 (302)nm UV lamp
MUV-T365	8W 365nm UV lamp
MUV-F21-254/365	21x21cm Filter for built-in 254/365nm UV Transilluminator (with stainless steel frame)
MUV-F21-312	21x21cm Filter for built-in 312(302)nm UV Transilluminator (with stainless steel frame)



MUV21-CP-01  
MUV26-CP-01



MUV21-CP-02  
MUV26-CP-02

## Blue Light Technology

Blue light technology allows you to view your DNA/RNA bands without causing photo nicking damage to your samples. Two series is designed for wide range of application: the SafeBlue series and BluView series.

The amazing SafeBlue product series utilize the power of blue light from the side, while BluView product series from bottom. Both SafeBlue and BlueView series allow you to run your standard electrophoresis experiment with immediate and outstanding results and not compromising your safety and protection.

SafeBlue system comprises the SafeBlue Illuminator, SafeBlue Electrophoresis System and SafeBlue Imager Systems. All three products are completely compatible with each other. Different accessories are also available should you need expansion or replacements. As for BluView system, packages of BluView Transilluminator, Mini Horizontal Gel Electrophoresis System, and power supply are available. New product, Major Blue, a two way fluorescence and loading dyes is now also on the market.

### Blue Light Technology

#### SafeBlue System 67-70

- SafeBlue Illuminator Electrophoresis System
- SafeBlue Imager System / Darkroom Viewer

#### Blue Light Illuminator 71-73

- Major Blue
- BluView Transilluminator



\*All images are for reference only, actual products might differ from the images.  
 \*Please visit our website at [www.majorsci.com](http://www.majorsci.com) for more product selection and detailed information.  
 \*Technical specification subject to change without notice.



# SafeBlue Illuminator Electrophoresis System

MBE-150  
MBE-150-PLUS

For MBE-150

The innovative SafeBlue Illuminator is an unit with combination of a small power supply with blue light illuminator. The system emits blue LED light which allows you to view your DNA/RNA bands without worrying about the harmful UV damage to your samples and eyes. SafeBlue Illuminator could also be used as a simple blue light illuminator to cut your samples from gels.

For MBE-150-PLUS

The SafeBlue Electrophoresis System also uses blue LED light to allow for immediate visualization of DNA/RNA bands while running agarose electrophoresis gel. The complete system comes with three different sizes of gel trays for your convenience of use, 150x70mm, 150x100mm and 150x150mm. The system is RoHS and CE compliant for environmental and safety concerns. Different accessories are also available for user to select.



4 in 1 feature allows you to run as you see in real-time motion



MBE-150

MBE-150 includes:

- 1 x SafeBlue Illuminator
- 1 x Power adaptor
- 1 x Power cord

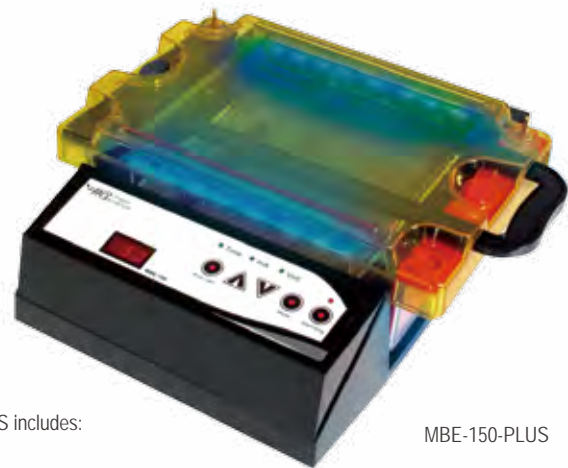

MBE-150-PLUS

MBE-150-PLUS includes:

- 1 x SafeBlue Illuminator
- 1 x SafeBlue Electrophoresis Tank
- 1 x Filter lid
- 1 x Threaded Black and Red Electrophoresis Cable
- 1 x 150x70mm UV tray
- 1 x 150x100mm UV tray
- 1 x 150x150mm UV tray
- 2 x 20 sample combs (1mm thick)
- 2 x UV tray casting dams
- 1 x SafeBlue electrophoresis gel tank image enhancer film



## Features

- Innovative - a complete 4-in-1 system (run, view, capture and cut gel) with simple and easy set up on the image capture/analysis software.
- Convenient - run as you see, real time visualization on your DNA/RNA band migration
- Compact - footprint smaller than most UV transilluminator, easy to move and ideal for limited bench top space
- Economical - an inexpensive imager system with digital camera. Multiple accessories are also available to increase experimental efficiency
- Safe - 470nm blue light less invasive than UV light
- Flexible - UV tray adaptors available, compatible with MJ-105A or Mupid 2.
- Versatile - support gel trays 150x150mm or smaller
- Optimized performance - Major Blue, SYBR series DNA/RNA stains, Novel Juice and Midori Green series
- Simple - DNA/RNA recovery method



## Specification

Cat. No.	MBE-150
Output Voltage / Inc.	10-150V / 1V
Output Current / Inc.	10-300mA / 1mA
Max. Power	30W
Operating Mode	Constant Voltage or Current
Timer	999 (min) with alarm / Continuous
Safety Device	No load detection
Crossover	Yes
Blue Light Wavelength	470nm
Operating Temperature	Ambient to 40°C
Dimension (WxLxH)	Approx. 11.5"x7.9"x3.2" (293x200x80mm)
Weight	Approx. 2.4lb (1.1kg)
Material	Polycarbonate housing and aluminum base plate
Power Adaptor	Input: 100-240VAC, 50/60Hz, 1.4A Output: 15VDC, 4.0A, 60W max.
Cat. No.	MBE-TANK
Dimension (WxLxH)	Approx. 10.4"x6.9"x3.5" (265x175x90mm)
Gel Dimension (WxL)	Approx. 5.9"x2.8" (150x70mm), 5.9"x3.9" (150x100mm), 5.9"x5.9" (150x150mm)
Maximum Sample	70 for 5.9"x2.8" (150x70mm) Tray (2x35 sample combs) 140 for 5.9"x3.9" (150x100mm) Tray (4x35 sample combs) 210 for 5.9"x5.9" (150x150mm) Tray (6x35 sample combs)
Buffer Volume	500ml
Construction	Acrylic (Injection molded construction) Durable, leak proof environment for complete safety and long life
Cassette Type Electrode	Inexpensive, easy to replace
Electrical Safety	Lid can only be fastened in one way Upon lid removal, power is disconnected from buffer chamber
Rapid Casting Gel	Use casting dams
Cat. No.	MBE-LID-Y1
Dimension (WxLxH)	Approx. 6.9"x10.6"x1.4" (176x268x35mm)
Filter Type	Amber filter (for dyes selection please refer to comparison table for various nucleic acid stain performance, <a href="#">page 69</a> )
Lid Filter Wiper	Used to remove condensation
Material	Polycarbonate

## Ordering Information

Cat. No.	Product Description
MBE-150	SafeBlue Illuminator
MBE-150-PLUS	SafeBlue Electrophoresis System, including SafeBlue Illuminator, electrophoresis gel tank, amber filter lid, image enhancer film and red/black cable
MBE-TLC	Package of MBE-TANK, MBE-LID-Y1, MBE-150-CABLE

## Bundle Packages

Cat. No.	Product Description
MBE-CP-01	Complete package of SafeBlue Electrophoresis System and SafeBlue 210 Imager System (MBE-IMG-CA)

\*For more information please refer to [Page 70](#)



## Accessories

Cat. No.	Product Description
MBE-TANK	ME15 Tank for SafeBlue without Lid and Red/Black Cable
MBE-LID-Y1	MBE-150 Lid,yellow
MBE-150-CABLE	Threaded Black and Red Electrophoresis Cable
MBE-TANK-01	120x155mm, shiny black protective film
MBE-150-01	Darkroom Viewer of MBE-150
MBE-150-02	165x140x19mm, Acrylics, cutting platform
MBE-150-3	Base unit platform protective film
ME15-UV15-TH01	ME15-UV15 Tray Holder, 2 cuts, cut size 109.5x60.5mm(For MJ-105 Trays)
ME15-UV15-TH02	ME15-UV15 Tray Holder, 1 cuts, cut size 130.5x122.5mm
MBE-G-Y1	Amber filter viewing glasses, 560nm
MST-50	Major Blue 50 µl
MST-1000	Major Blue 1000 µl

\* For more information of MBE-IMG-CA, please refer to SafeBlue Imager System.



MBE-150-01



MBE-TANK

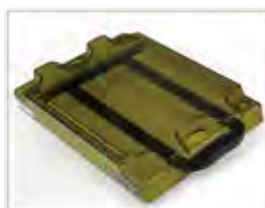

MBE-LID-Y1



MBE-150-CABLE



MBE-TLC



MBE-TANK-01



MBE-150-02



MBE-150-3



ME15-UV15-TH01



ME15-UV15-TH02



MBE-G-Y1

## Comparison table for various nucleic acid stain performance

Nucleic Acid Stain	Performance	Experimental Protocol		
		Pre-staining	Post Staining	Sample Staining
Major Blue	Excellent			√
SYBR® Green I (DNA)	Excellent	√	√	√
SYBR® Green II (RNA)	Excellent		√	√
SYBR® Gold	Excellent	√	√	
Midori Green Direct	Excellent			√
Hydra Green™ Safe DNA Dye	Excellent	√	√	
HD Green™ DNA Stain	Excellent	√	√	
Novel Juice	Excellent			√
SafeView DNA Stain	Good	√		
SYBR® Safe	Good	√	√	
Midori Green	Good	√	√	
Midori Green Advanced	Good	√	√	
Serva DNA Stain Clear G	Good	√	√	
GelGreen™	Good	√	√	
GelRed™	NR	√	√	
Ethidium Bromide	NR	√	√	
HealthView™	NR	√		

\*NR= Not recommended\*

Note: SafeBlue system is best use with Major Blue nucleic acid stains (Page 71)

MBE-150-PLUS Innovative Electrophoresis System

1. Early detection of running error (run as you see)
2. Prevention for breaking gel- no more gel transferring (no more gloves!!)
3. Time saving gel staining & de-staining
4. Compact in size (no large lab area required)

**SafeBlue System**

SafeBlue Electrophoresis System

+

SafeBlue Imager System

2 for all

**Gel and Sample Preparation**

**Electrophoresis Running**

**Sample Observation Image Capture**

5 for all

**Traditional Method**

Gel Electrophoresis System + Power Supply + Shaker + UV Transilluminator + Gel Documentation System



# SafeBlue Imager System/ Darkroom Viewer

## MBE-IMG-CA

The SafeBlue Imager System offers two selections for your convenience and preference. The compact digital camera allows you to take pictures from the camera and stores in the memory card without any hassle. The portable and light design allows you to carry it with ease. The digital camera provides a superb resolution of 18 megapixels. The darkroom viewer provides a darkroom environment for you to view the migrating DNA with ease. The SafeBlue Imager System completes the SafeBlue electrophoresis series for all your needs - from gel casting, gel electrophoresis to gel documentation; all in one system. The complete SafeBlue Imager System not only saves your lab bench space, but also provides excellent portability to move from lab to lab.

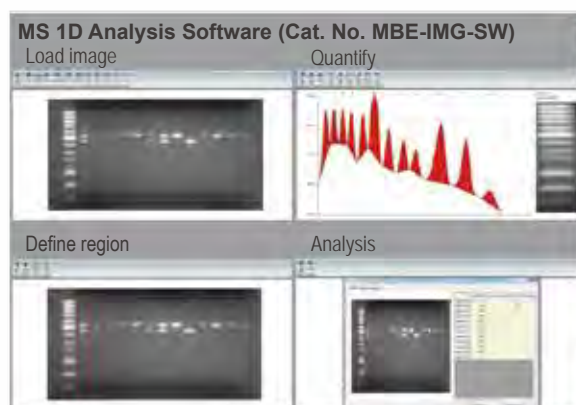

MBE-CP-01

### Features

- Light weight and space saving design
- Ready to use out of the box: just connect and capture
- 18 megapixel digital camera
- Can be operated PC free
- Designed for SafeBlue Electrophoresis System to complete cast, run, and capture



Easy handling and set up for gel imaging

MBE-IMG-CA-01



DI-EB49



DI-SG49



DI-AM49



MBE-G-Y1

### Specification

Cat. No.	MBE-IMG-CA
<b>Camera Specification</b>	
Camera Type	18.0MP digital camera, Wi-Fi function
Effective Pixels	Approx. 18.0 Megapixels
Sensor	CMOS sensor (supporting Hybrid CMOS AF II)
Max. Aperture	f/3.5-6.3 (IS STM Lens)
Shutter Speed	1/4000 - 30sec. (available range varies by shooting mode)
Storage Media	SD memory card, Wi-Fi to PC, Smartphone or Tablet
Computer Interface	USB 2.0 Hi-speed (mini-B jack) or Wi-Fi connection
Video Out	Full HD / HD / NTSC / PAL
Image Resolution	5184x3456
Lens	35mm film equivalent focal length, approx. 1.6 times the lens focal length
File Format	Designed rule for Camera File system 2.0
Data Type	JPEG, RAW(14-bit, Canon original), RAW+JPEG simultaneous recording possible
Filter (For Camera, Optional)	"EtBr filter / SYBR Green filter / Amber Filter *ordered separately"
<b>Darkroom</b>	
Dimension (WxLxH)	Approx. 13.4"x7.7"x15.8" (340x195x400mm)
Material	Acrylonitrile Butadiene Styrene (ABS)
Weight	Approx. 1.8lb (0.8Kg)
Camera Adapter Material	Aluminum
<b>Cat. No. MBE-150-01</b>	
Dimension (WxLxH)	Approx. 8.4"x14.3"x11.4" (213x362x290mm)
Material	Acrylonitrile Butadiene Styrene (ABS)
Weight	Approx. 1.6lb (0.72Kg)

### Ordering Information

Cat. No.	Description
MBE-IMG-CA	SafeBlue 210 Imager System with 18.0 megapixel digital camera
MBE-IMG-CA-01	SafeBlue 210 Imager System holder kit, includes hood and camera adapter only
MBE-150-01	Darkroom Viewer of MBE-150

\*For more information please refer to Page 69.

### Bundle Packages

Cat. No.	Description
MBE-CP-01	Complete package of MBE-150-PLUS and MBE-IMG-CA

### Accessories

Cat. No.	Product Description
MBE-G-Y1	Amber Filter Viewing Glasses, 560 nm
MBE-IMG-SW	MS 1D Analysis Software
DI-TOTALLAB	Totallab 1D Gel Analysis Software
<b>Filter (for camera) *ordered separately</b>	
DI-EB49	EtBr filter, 49mm
DI-SG49	SYBR Green filter, 49mm
DI-AM49	Amber filter 580nm, 49mm

# Major Blue

MST-50  
MST-1000

Fluorescence and Loading Dyes in One Vial  
2-in-1 Convenience at Your Fingertips

Major Science offers Major Blue stain, the highly sensitive fluorescent nucleic acid gel stains for staining DNA in electrophoresis gels. It is much safer than ethidium bromide: non-toxic, non-mutagenic, and non-carcinogenic.

Major Blue stain contains different tracking dyes, and is easy to detect nucleic acids in gels and monitor the DNA migration during the electrophoresis runs.

Major Blue stain can be excited by blue light transmission, which can prevent DNA from damage. It is compatible with our SafeBlue product: SafeBlue System, Blue Light Illuminator.

**Features:**

- Safety - Absence of mutagenicity
- Sensitivity - High degree of sensitivity as Ethidium Bromide(EtBr).
- Convenience - Ready to Use; Same application procedures as the 6X Loading Dye.
- Economic - Non-hazardous product; No expenses required for the waste management.
- Excitation wavelength - UV 300nm, Blue light 470nm
- Emission wavelength - UV 495/537nm, Blue light 580nm

**Ordering Information**

Cat. No.	Product Description
MST-50	Major Blue 50 µl
MST-1000	Major Blue 1000 µl



Cloning Efficiency  
PCR fragments separated on agarose gels containing EtBr or Major Blue were exposed to UV or blue light for specific amounts of time, then used for subcloning. Even brief EtBr/UV treatment yielded significantly fewer CFUs.

**Ultra-Sensitive DNA Staining Reagent**

Sensitivity > 1ng. More sensitive than EtBr(1ng) and Sybr Safe (3ng)



Concentration: ng/µl  
Volume: 6µl/lane  
LED Wavelength: 470nm  
M: 1kb DNA Ladder

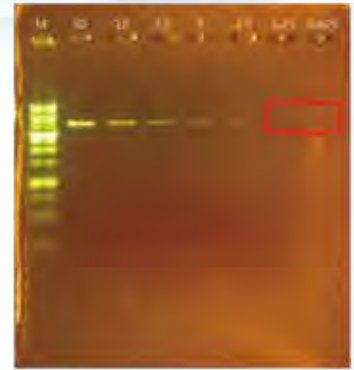

Sensitivity Comparison under the Blue Light Transilluminator: Major Blue (left) and Sybr Safe (right)



Concentration: ng/µl  
Volume: 6µl/lane  
UV Wavelength: 300nm  
Exposure: 1min  
M: 1kb DNA Ladder



Sensitivity Comparison under the UV Transilluminator: Major Blue (left) and Sybr Safe (right)

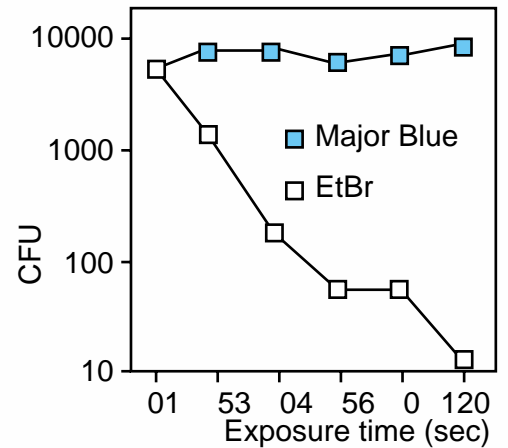

**5ul PCR Product**

**1ul Major Blue**

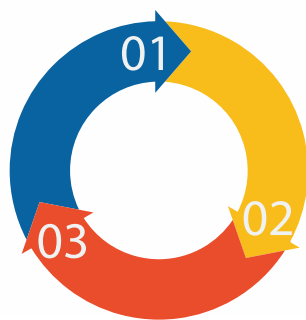

Staining  
Mixing Major Blue & PCR product!



Loading  
Load 6µl stained PCR product onto agarose gel. Run gel electrophoresis.



Seeing  
Imagine gel under UV or Blue Light system.





NEW

## BluView Transilluminator

### MBE-200A

The advanced BluView Transilluminator separates its 580nm amber lid from the body, and makes the illuminator thinner and more lightweight. Like the last generation of BluView Transilluminator, it is packed with safe 470nm blue LED light. With imaging size of 153x153mm, you could fit any small midi size gel on top of the transilluminator. The BluView Transilluminator is also compatible with our imaging system such as Digimage System and Smartview Simple System.

#### Features

- Thinner and more lightweight body
- Easy to carry in between labs
- Aluminum alloy casing design
- Low heat dispersion
- Energy saving product
- 470nm harmless blue light for direct human contact

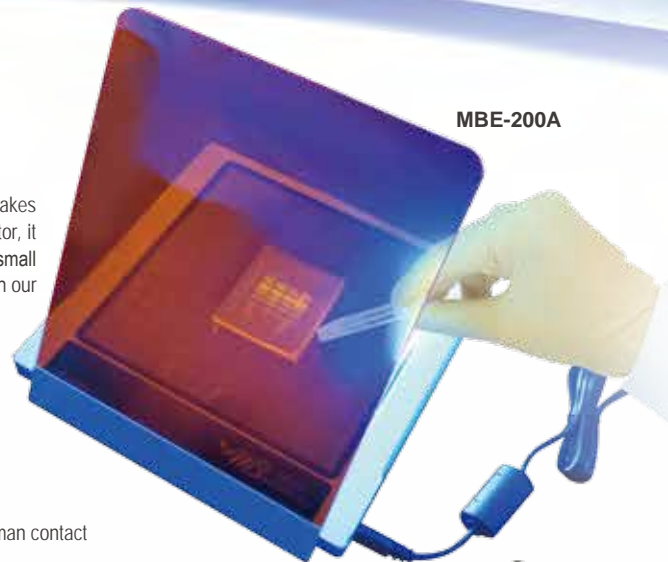

CE

## BluView Transilluminator

### MBE-300

Major Science BluView Transilluminator uses the harmless blue LED lights to replace the aggressive UV lights, and allows you to directly view the experiment result without wearing any UV protection equipment. With its compact size and light weight, the transilluminator occupies little of your lab bench and is easy to move from lab to lab.

Package with our Mini Horizontal Gel Electrophoresis System is available to perform real time observation and early mistake detection.

#### Features

- Portable size and light weight
- Safe 470nm blue light wavelength
- Slim design fits in most of electrophoresis tanks
- Real time observation
- Efficient and early mistake detection
- Ultra high light uniformity

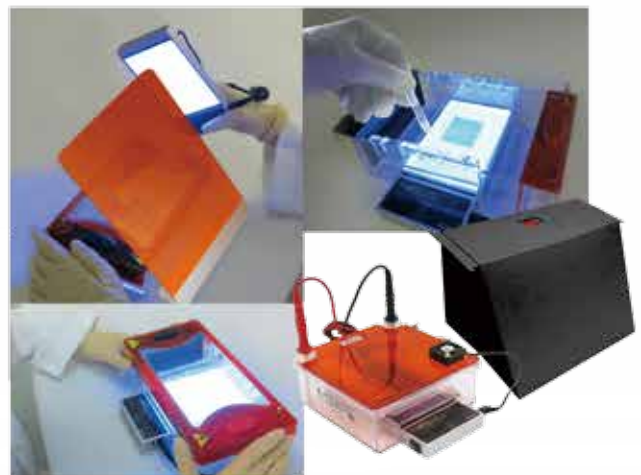



## Specification

Cat. No.	MBE-200A	MBE-300
Dimension (WxLxH)	Approx. 7.9"x7.9"x0.6" (200x200x13.9mm)	Approx. 3.4"x6.7"x1" (86x170x25mm)
Viewing Area (WxL)	6"x6" (153x153mm)	Approx. 4.4"x2.9" (112x74.6mm)
Blue Light Source	15W	20W
Illuminator Base Design		Flat Bed
Blue Light Wavelength		470nm
Automatic Shutdown		Approx. 6 min
Material		Aluminum Alloy
Power		DC 12V, 2A
Weight	Approx. 1.68lb (760g)	Approx. 0.75lb (338g)

## Ordering Information

Cat. No.	Product Description
MBE-200A	Advanced BluView Transilluminator, 470nm, viewing area 153x153 mm, amber filter(MBE-LID-AM580), synthetic paper hood are included
MBE-300	BluView Transilluminator, 470nm, viewing area 112x74.6 mm, amber filter(MBE-LID-AM580) is included

## Bundle Packages

Cat. No.	Product Description
MJA-MBEP	Package of MJ-105A and MBE-300; amber filter lid with fan, synthetic paper hood are included
MJAE-100P	Package of MJ-105A, MP-100, and MBE-300; amber filter lid with fan, synthetic paper hood are included
MJAE-Mini300	Package of MJ-105A, MINI-300, and MBE-300; amber filter lid with fan, synthetic paper hood are included



MJAE-100P



MJAE-Mini300



MJA-MBEP

## Accessories

Cat. No.	Product Description
MJ-105A	Transparent Mini Horizontal Electrophoresis System
MBE-102	LLid with 580nm amber filter and evaporation fan for ME10-7-10
MBE-103	Lid with 580nm amber filter and evaporation fan for ME7-7-10
MBE7-TANK	ME7-7-10 Electrophoresis tank only, without Lid and Red / Black Cable
MBE10-TANK	ME10-7-10 Electrophoresis tank only, without Lid and Red / Black Cable
MBE-150-CABLE	Threaded Black and Red Electrophoresis Cable
MJ-LID-AM580	580nm amber filter lid with fan, suitable for MJ-105A
MBE-LID-AM580	An inclined 580nm amber filter, suitable for MBE-200A and MBE-300
MBE-HOOD	Synthetic paper hood



MJ-105A



MJ-LID-AM580



MBE-102



MBE-103



MBE7-TANK



MBE10-TANK



MBE-150-CABLE



MBE-LID-AM580

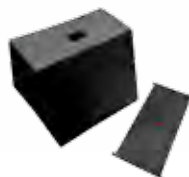

MBE-HOOD

## Mixer/Temperature Control

Dry Bath, Incubator, Shaker, Stirring Water Bath

Major Science designs and manufactures a comprehensive range of mixing and temperature control equipments for use in the fields of analytical, diagnostic, and research laboratory. Designed with the user's needs in mind, our full product portfolio includes dry bath incubators, ovens, shakers, and water baths. This inter-related line features consistent performance, long durability, and outstanding stability.

### Mixer/Temperature Control

#### ▣ Dry Bath Incubator

75-87

- Mini Heating Dry Bath Incubator
- Mini Cooling Dry Bath Incubator
- Genius Dry Bath Incubator
- Elite Dry Bath Incubator
- Ultimate Dry Bath Incubator
- Dry Bath Block & Beads



#### ▣ Incubator

88-90

- MS Mini Incubator
- MS Oven
- MS Hybridization Oven



#### ▣ Shaker

91-92

- MS Orbital Shaker
- MS Reciprocal Shaker
- MS Rocking Shaker



#### ▣ Stirring Water Bath

93-94

- 10L Stirring Water Bath
- 20L Stirring Water Bath



\*All images are for reference only, actual products might differ from the images.

\*Please visit our website at [www.majorsci.com](http://www.majorsci.com) for more product selection and detailed information.

\*Technical specification subject to change without notice.

# Mini Heating Dry Bath Incubator

## MD-MINI

The Mini Heating Dry Bath Incubator incorporates innovative ideas of compactness, performance and versatility. This palm-sized yet powerful device is designed to maximize benchtop space and enhance research productivity with ultra-precise temperature control. The interchangeable ability of heating blocks in various size permits accommodation of versatile tube sizes. Moreover, turn it into a water bath or bead bath with optional metallic thermal beads.



MD-MINI



Clear block cover ensures temperature uniformity



MD-MINI-LID



MD-MINI-CAR-ADAPTER



### Features

- Small size, fits in your palm
- User temperature calibration
- Single molded chamber, no cracks or welds
- PTFE coated chamber resists stains
- Can be used as a mini water bath or bead bath
- Outstanding heating rate
- Different sizes of heating block available for selection
- Clear cover to ensure temperature uniformity
- Optional in-car power adaptor provides portability on the road

### Specification

Cat. No.	MD-MINI
Display	LED
Power	50W
Dimension (WxLxH)	Approx. 6"x4.9"x3.8" (153x125x97mm)
Controller	Digital microprocess controller
Heating Chamber	Molded waterproof aluminum alloy coated with PTFE
Temperature Control Range	5°C above ambient to 100°C
Temperature Increment	0.1°C
Temperature Uniformity	± 0.20°C at 37°C
Temperature Accuracy	± 0.25°C at 37°C
Temperature Calibration	Yes
Timer	9999 (min) / Continuous
Safety	Leak proof heating chamber
	Over temperature protection
Operating Temperature	Ambient to 40°C
Special Feature	Used as water bath or bead bath
Block Material	Aluminum alloy
Block Type	Standard and customized type are available
Rated Voltage	100V-240V~
Weight	Approx. 1.3lb (0.6kg)
<b>Blocks</b>	
Block Material	Aluminum alloy
Dimension (WxLxH)	Approx. 1.9"x2.8"x1.3" (47x71x32mm) / Approx. 1.9"x2.8"x3" (47x71x75mm)
Block Lifter Well	Yes
Thermometer Well	Yes

### Ordering Information

Cat. No.	Product Description
MD-MINI	Mini Heating Dry Bath Incubator; without block

### Accessories

Cat. No.	Product Description
MD-MINI-B01	For 0.2ml tube (PCR strip tube), 32 wells, φ6.35mm, depth 19mm, (WxLxH) 47x71x32mm
MD-MINI-B02	For 1.5ml tube, 12 wells, φ10.8mm, depth 28.5mm, (WxLxH) 47x71x32mm
MD-MINI-B03	For 15ml tube, 6 wells, φ17.3mm, depth 70mm, (WxLxH) 47x71x75mm
MD-MINI-B04	For 50ml tube, 2 wells, φ29.2mm, depth 72mm, (WxLxH) 47x71x75mm
MD-MINI-B05	For 0.5ml tube, 12 wells, φ8.0mm, depth 25mm, (WxLxH) 47x71x32mm
MD-MINI-B06	For 2.0ml or 1.5ml tube, 12 wells, φ11.0mm, depth 30mm, (WxLxH) 47x71x32mm
MD-MINI-B07	For 1.5ml tube, 12 wells, φ10.9mm, depth 30mm, (WxLxH) 47x71x32mm
MS-BL95-E	Block Lifter, 95mm length, with E-type retaining rings
MD-MINI-LID	MD-MINI lid, (WxLxH) 83x58.5x31.5mm
MD-MINI-CAR-ADAPTER	Car adapter for MD-MINI and MC-0203, 1.5M

\* For a complete list of accessories, please refer to [Page 84-87](#)



# Mini Cooling Dry Bath Incubator

MC-0203

The product line Mini Cooling Dry Bath Incubator is the mini-series of our ultimate dry bath. It is designed to meet the requirement of accurate temperature control, ease of data transferring and programming, small foot print and ease of use. Experience the exceptional heating/cooling rate with quick start feature and the portability to work your sample on the road! Perfect instrument can be used in QC process such as in food industry.



MC-0203



Can be used as a bead bath



Quick start program

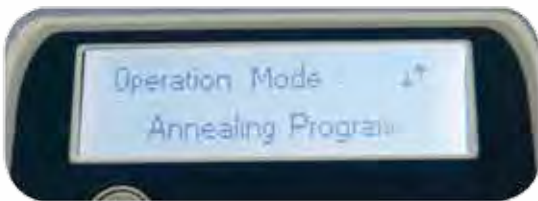

Annealing program

## Functional control software

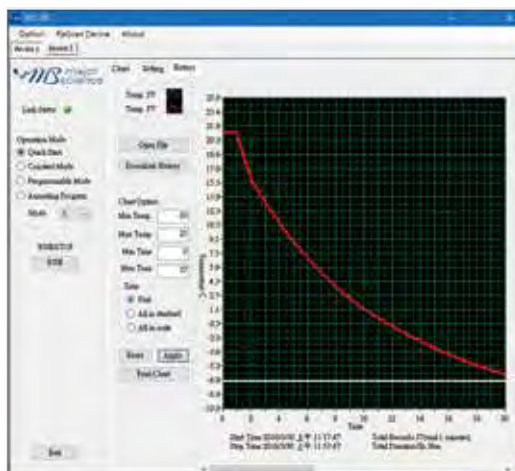

- Temp. set value: -6°C
- Initial temp. value: 20.6°C
- Block type: MD-MINI-B02
- Process time: Approx. 20mins

## Functional control software for cooling and heating models

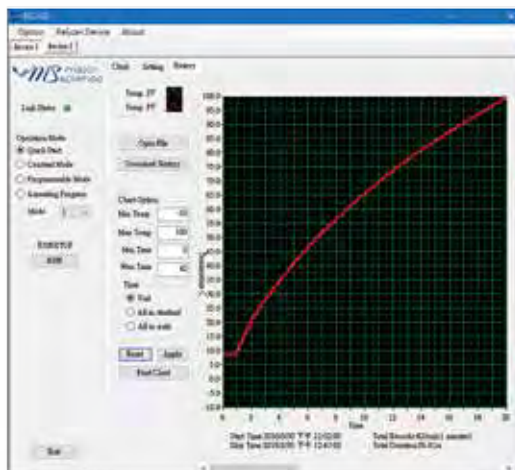

- Temp. set value: 100°C
- Initial temp. value: 9°C
- Block type: MD-MINI-B02
- Process time: Approx. 20mins

### Features

- Small size, fits in your palm
- User temperature calibration
- Single molded chamber, no cracks or welds
- PTFE coated chamber resists stains
- Can be used as a mini water bath or bead bath
- Outstanding heating and cooling rate
- Different sizes of aluminum alloy block available for selection
- Clear cover to ensure temperature uniformity
- Quick start / Constant mode / programmable mode / Annealing program operation mode
- Optional in car power adaptor provides portability on the road

## Specification

Cat. No.	MC-0203
Display	LCD
Power	max. 60W
Dimension (WxLxH)	Approx. 5.3"x6"x7.3" (135x152x185mm) (excluding lid)
Controller	High performance 32 bits microprocessor
Heating /Cooling Chamber	Molded waterproof aluminum alloy coated with PTFE
Temperature Control Range	30°C below ambient temperature (minimum -10°C) to 100°C
Temperature Increment	0.1°C
Temperature Uniformity	± 0.2°C at 37°C
Temperature Accuracy	± 0.25°C at 37°C
Temperature Calibration	Yes
Heating Rate	Max. 5°C per min
Cooling Rate	Max. 4°C per min
Timer	9999 (min)
Cooling/ Heating Parts	Peltier / Heating element
Operation Mode	Constant operation: constant temperature (-10°C to 100°C)
	Program operation: 1-4 steps and up to 9 cycles
	Annealing program
	Quick start program: 4°C, 16°C, 37°C, 56°C, 95°C pre-set
Safety	Leak proof heating chamber
Operating Temperature	Ambient to 40°C
Special Feature	Can be used as water bath or bead bath incubator
Block Material	Aluminum alloy
Block Type	Standard and customized type are available
PC Connection	USB
Weight	Approx. 2.9lb (1.3kg)



Annealing Program

Initial Temp.	95.0
Descending Temp.	5.0
Holding Time.	5
Final Temp.	4.0



As a water bath

## Ordering Information

Cat. No.	Product Description
MC-0203	Mini Cooling Dry Bath Incubator, programmable cooling and heating; without block

## Accessories

Cat. No.	Product Description
MC-0200-SW	Functional control software for Mini Cooling Incubator including a USB cable
MD-MINI-B01	For 0.2ml tube (PCR strip tube), 32 wells, φ6.35mm, depth 19mm, (WxLxH) 47x71x32mm
MD-MINI-B02	For 1.5ml tube, 12 wells, φ10.8mm, depth 28.5mm, (WxLxH) 47x71x32mm
MD-MINI-B03	For 15ml tube, 6 wells, φ17.3mm, depth 70mm, (WxLxH) 47x71x75mm
MD-MINI-B04	For 50ml tube, 2 wells, φ29.2mm, depth 72mm, (WxLxH) 47x71x75mm
MD-MINI-B05	For 0.5ml tube, 12 wells, φ8.0mm, depth 25mm, (WxLxH) 47x71x32mm
MD-MINI-B06	For 2.0ml or 1.5ml tube, 12 wells, φ11.0mm, depth 30mm, (WxLxH) 47x71x32mm
MD-MINI-B07	For 1.5ml tube, 12 wells, φ10.9mm, depth 30mm, (WxLxH) 47x71x32mm
MS-BL95-E	Block Lifter, 95mm length, with E-type retaining rings
MD-MINI-LID	MD-MINI lid, (WxLxH) 83x58.5x31.5mm
MD-MINI-CAR-ADAPTER	Car adapter for MD-MINI and MC-0203, 1.5M

\* For a complete list of accessories, please refer to [Page 84-87](#)



MD-MINI-LID



MD-MINI-CAR-ADAPTER





# Genius Dry Bath Incubator

## MD series

The Genius Dry Bath Incubators come in either single or dual block models, along with a complete set of interchangeable blocks. It is designed for a variety of applications, including restriction digest, denaturing DNA melting agar, coagulation studies, hybridization and hot start thermo-cycled reaction. The microprocessor controller offers highly accurate temperature control, rapid heating and excellent stability. The temperature can be set in increments of 0.1°C from 5°C above ambient to 150°C. An optional temperature probe is available to place directly in samples. A timer can be set from 1- 999mins. The MD series can be used as a mini water bath or bead bath. Optional function control software allows the dry bath incubator to perform real-time data recording through a PC.



FC CE



**MD-01N**

**MD-02N**

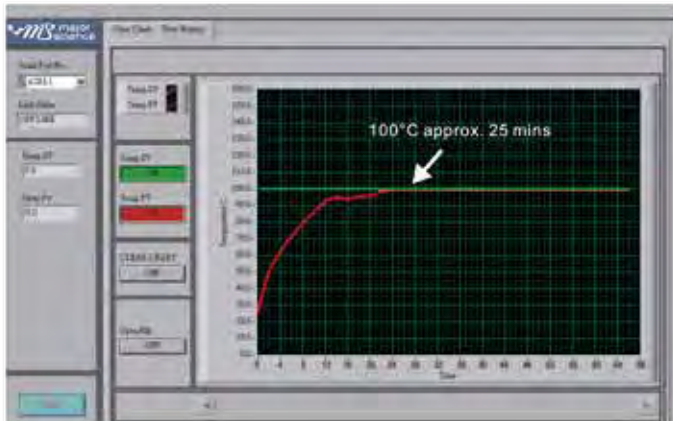

■ Temp. set value:100°C  
 ■ Initial temp. value:25°C  
 Block model: MD-B1.5  
 Process time: Approx. 25mins

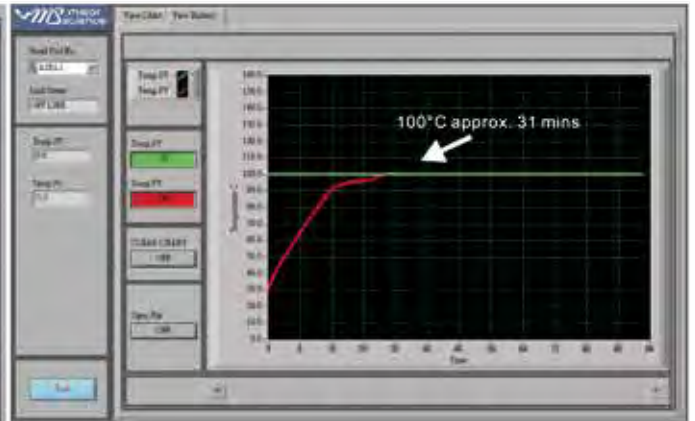

■ Temp. set value:100°C  
 ■ Initial temp. value:30°C  
 Block model: MD-B1.5  
 Process time: Approx. 31mins

**Features**

- Digital microprocessor offers precise performance control
- Highly accurate temperature control and broad control range
- Rapid heating rate
- Digital LED display & timer
- User temperature calibration
- Molded aluminum alloy chamber
- Function control software available



Can be used as a water bath



## Specification

Cat. No.	MD-01N (Single Block)	MD-02N (Dual Block)
Display	LED	
Power	125W	200W
Dimension (WxLxH)	Approx. 7.9"x11.7"x3.2" (200x298x80mm)	
Controller	Digital microprocess controller	
Heating Chamber	Molded Waterproof aluminum alloy coated with PTFE	
Temperature Control Range	5°C above ambient to 150°C	
Temperature Increment	0.1°C	
Temperature Uniformity	±0.2°C at 37°C	
Temperature Accuracy	±0.2°C at 37°C	
Temperature Calibration	Yes	
Timer	999 (min) / Continuous	
Safety	Leak proof heating chamber	
	Over temperature protection	
	SSR failure detection	
Operating Temperature	Ambient to 40°C	
Special Feature	Can be used as water bath or bead bath incubator	
Block Material	Aluminum alloy	
Block Type	Standard and customized types are available	
PC Connection	RS232	
Rated Voltage	110V / 220V-	
Weight	Approx. 4.6lb (2.1kg)	Approx. 6.2lb (2.8kg)
<b>Blocks</b>		
Block Material	Aluminum alloy	
Dimension (WxLxH)	Approx. 3.1"x4.1"x2" (79x104x50mm) for standard type	
Block Lifter Well	Yes	
Thermometer Well	Yes (except microplate blocks)	



with beads



with water



with block



MD-01N / MD-02N  
with MD-P01



MD-P01

## Ordering Information

Cat. No.	Product Description
MD-01N-110/220	Genius Dry Bath Incubator (One block unit); without block
MD-02N-110/220	Genius Dry Bath Incubator (Dual block unit); without block

## Accessories

Cat. No.	Product Description
MD-P01	Thermocouple
MD-RS232	RS 232 cable
MD-PCSW	Function control software package
MD-PCSW-R	Function control software package; including a RS232 cable
MD-MP01-S	For microplate; titerplate (Plain Block for Single Block unit only)
MD-MP01-D	For microplate; titerplate (Dual Block unit only)
MD-MP02-S	For 96 wells deep microplate or PCR plate ( for Single Block unit only)
MD-MP02-D	For 96 wells deep microplate or PCR plate ( for Dual Block unit only)
MD-B0.2	For 0.2ml tube, 64 wells (or 0.2ml PCR strip tube for 8 wells x 8)
MD-B0.5	For 0.5ml tube, 20 wells
MD-B1.5	For 1.5ml tube, 20 wells
MD-B0.5+1.5	Combination: for 0.5ml tube, 12 wells; and for 1.5ml tube, 12 wells (on the same side)
MD-B0.5/1.5	One side for 1.5 or 2.0ml tube, 20 wells and another side for 0.5ml tube, 30 wells (on the opposite side)
MD-B13	Well size 13mm, 20 wells
MD-B17	For 15ml centrifuge tube, 12 wells
MD-B20	Well size 20mm, 12 wells
MD-B25	Well size 25mm, 6 wells
MD-B29	For 50ml centrifuge tube, 4 wells

\* For a complete list of accessories, please refer to Page 84-87

# Elite Dry Bath Incubator

## EL series

The Elite Dry Bath Incubator comes in single or dual block modes along with a comprehensive set of interchangeable blocks. It is designed for a variety of applications, including restriction digest, denaturing DNA, BUN, melting agar, coagulation studies, hybridization and hot start thermo-cycled reaction. Elite Dry Bath is recognized as the finest, fastest heating and smallest foot print dry bath incubator. In addition, the aluminum blocks can be removed for the use of a mini water bath or a bead bath. The temperature setpoint can be set in increments of 0.1°C from 5°C above ambient to 150°C. Optional PC control software allows the dry bath incubator to perform real time data recording through a PC.

FCCE



EL-01



EL-02

### EL-01

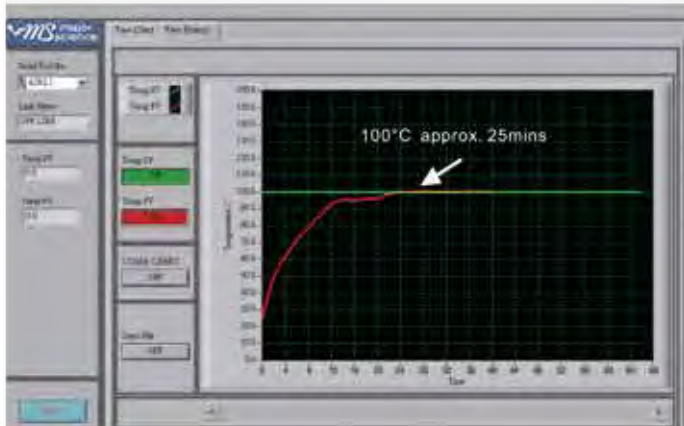

- Temp. set value: 100°C
- Initial temp. value: 25°C
- Block model: MD-B1.5
- Process time: Approx. 25mins

### EL-02

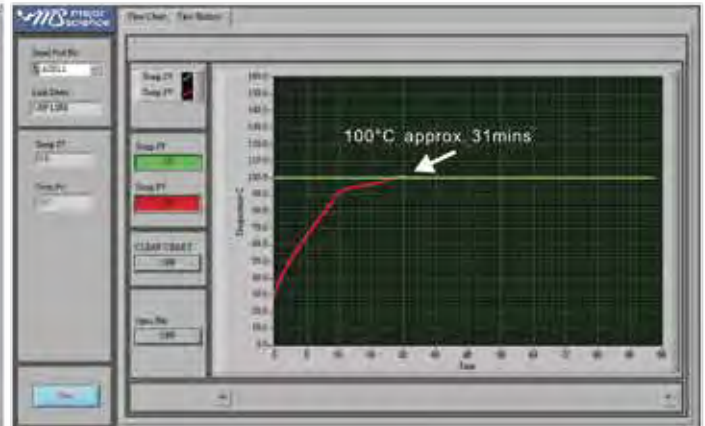

- Temp. set value: 100°C
- Initial temp. value: 30°C
- Block model: MD-B1.5
- Process time: Approx. 31mins

### Features

- Digital microprocessor controller confers performance and precise control
- Broad temperature control range & guaranteed uniformity
- Excellent heating rate
- Large LCD screen for instant observation
- User temperature calibration
- Can be used as a water bath or bead bath
- Molded aluminum alloy chamber
- Optional PC control software available



Can be used as a bead bath

## Specification



with beads



with water



with block

Cat. No.	EL-01 (Single Block)	EL-02 (Dual Block)
Display	LCD	
Power	125W	200W
Dimension (WxLxH)	Approx. 6"x5.9"x5.3" (152x150x135mm)	Approx. 6"x9.1"x5.3" (152x230x135mm)
Controller	Digital microprocess controller	
Heating Chamber	Molded Waterproof aluminum alloy coated with PTFE	
Temperature Control Range	5°C above ambient to 150°C	
Temperature Increment	0.1°C	
Temperature Uniformity	± 0.2°C at 37°C	
Temperature Accuracy	± 0.2°C at 37°C	
Temperature Calibration	Yes	
Timer	99 (hr): 59 (min) / Continuous	
Safety	Leak proof heating chamber	
	Over temperature protection	
	SSR failure detection	
Operating Temperature	Ambient to 40°C	
Special Feature	Used as water bath or bead bath incubator	
Block Material	Aluminum alloy	
Block Type	Standard and customized type are available	
PC Connection	RS232	
Rated Voltage	110V / 220V-	
Weight	Approx. 4.6lb (2.1kg)	Approx. 6.1lb (2.8kg)
<b>Blocks</b>		
Block Material	Aluminum alloy	
Dimension (WxLxH)	Approx. 3.1"x4.1"x2" (79x104x50mm) for standard type	
Block Lifter Well	Yes	
Thermometer Well	Yes (except microplate blocks)	

## Ordering Information

Cat. No.	Product Description
EL-01-110/220	Elite Dry Bath Incubator ( One block unit ); without block
EL-02-110/220	Elite Dry Bath Incubator ( Dual block unit ); without block

## Accessories

Cat. No.	Product Description
MD-RS232	RS 232 cable
MD-PCSW	Function control software package
MD-PCSW-R	Function control software package; including a RS232 cable
MD-MP01-S	For microplate; titerplate (Plain Block for Single Block unit only)
MD-MP01-D	For microplate; titerplate (Dual Block unit only)
MD-MP02-S	For 96 wells deep microplate or PCR plate ( for Single Block unit only)
MD-MP02-D	For 96 wells deep microplate or PCR plate ( for Dual Block unit only)
MD-B0.2	For 0.2ml tube, 64 wells (or 0.2ml PCR strip tube for 8 wells x 8)
MD-B0.5	For 0.5ml tube, 20 wells
MD-B1.5	For 1.5ml tube, 20 wells
MD-B0.5+1.5	Combination: for 0.5ml tube, 12 wells; and for 1.5ml tube, 12 wells (on the same side)
MD-B0.5/1.5	One side for 1.5 or 2.0ml tube, 20 wells and another side for 0.5ml tube, 30 wells (on the opposite side)
MD-B13	Well size 13mm, 20 wells
MD-B17	For 15ml centrifuge tube, 12 wells
MD-B20	Well size 20mm, 12 wells
MD-B25	Well size 25mm, 6 wells
MD-B29	For 50ml centrifuge tube, 4 wells

\* For a complete list of accessories, please refer to [Page 84-87](#)



# Ultimate Dry Bath Incubator

MC-01N

Ultimate Dry Bath Incubator is available with different heating and cooling profiles, along with a broad selection of interchangeable blocks. The model is designed for a variety of applications including ligation, restriction digest, denaturing DNA, BUN, melting agar, coagulation studies, hybridization and hot start thermo-cycled reaction. The built-in 2.6" LCD screen permit instant viewing and selection of operation modes: constant, programmable and annealing. The microprocessor controller offers performance, precise control as well as rapid heating and cooling efficiency with excellent stability. The temperature can be set in 0.1°C increments, from -10°C to 100°C. Optional PC control software is available for real time data logging.



CE



MC-01N



■ Temp. set value: 100°C  
 ■ Initial temp. value: 25°C  
 Block model: MC-B0.2+0.5+1.5  
 Process time: Approx. 17mins

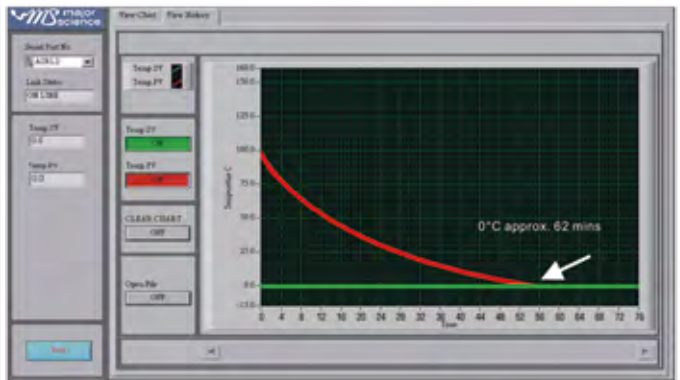

■ Temp. set value: 0°C  
 ■ Initial temp. value: 100°C  
 Block model: MC-B0.2+0.5+1.5  
 Process time: Approx. 62mins

## Features

- Digital microprocessor offers performance and precise control
- Broad temperature control range & guaranteed uniformity
- Highly efficient heating & cooling rates
- Large LCD screen for easy selection of operation modes and setting inputs
- User temperature calibration
- Also a mini water bath and bead bath
- Optional PC control software available

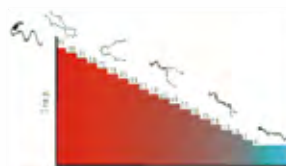

## Annealing Program

Initial Temp.	95.0
Descending Temp.	5.0
Holding Time.	5
Final Temp.	4.0

## Specification

Cat. No.	MC-01N
Chamber Dimension (WxLxH)	Approx. 5.1"x3.5"x2" (130x90x50mm)
Display	2.6" LCD
Power	400W
Dimension (WxLxH)	Approx. 7.9"x11.6"x5.5" (200x295x140mm)
Controller	Digital microprocess controller
Heating Chamber	Molded Waterproof aluminum alloy coated with PTFE
Temperature Control Range	30°C below ambient temperature ( minimum -10°C ) to 100°C
Temperature Increment	0.1°C
Temperature Uniformity	± 0.2°C at 37°C
Temperature Accuracy	± 0.2°C at 37°C
Temperature Calibration	Yes
Operation Mode	Constant operation: constant temperature ( -10°C to 100°C ); Timer: 9999 (min)
	Program operation: 1-4 steps and up to 9 cycles; timer: 9999 (min)
	Annealing program
Safety Device	Leak proof heating chamber
Operating Temperature	Ambient to 40°C
Special Feature	Can be used as water bath or bead bath incubator
Block Material	Aluminum alloy
Block Type	Standard and customized type are available
PC Connection	RS232
Rated Voltage	110V / 220V~
Weight	Approx. 17.6lb (8kg)
<b>Blocks</b>	<b>Ultimate MC Block</b>
Dimension (WxLxH)	Approx. 3.5"x5.1"x1.8" (89x129x46mm)
Block Material	Aluminum alloy
Block Lifter Well	Yes
Thermometer Well	Yes ( except microplate blocks )



with water



with beads



with block

## Ordering Information

Cat. No.	Product Description
MC-01N-110/220	Ultimate Dry Bath Incubator; without block

## Accessories

Cat. No.	Product Description
MC-RS232	RS 232 cable
MC-PCSW	Function control software package
MC-PCSW-R	Function control software package; including a RS232 cable
MC-MP01	For microplate; titerplate ( Plain Block )
MC-MP02	For 96 wells deep microplate or PCR plate
MC-B0.5	For 0.5ml, 30 wells
MC-B1.5	For 1.5 or 2.0ml, 30 wells
MC-B0.5+1.5	Combination: for 1.5ml or 2.0ml tube, 15 wells and 0.5ml tube, 15 wells (on the same side)
MC-B0.2+0.5+1.5	Combination: 0.2ml tube (or strip tube for 8 wells ), 24 wells; 1.5ml or 2.0ml tube, 10 wells and 0.5ml tube, 10 wells (on the same side)
MC-B13	Well size 13mm, 30 wells
MC-B17	For 15ml centrifuge tube, 15 wells
MC-B20	Well size 20mm, 15 wells
MC-B25	Well size 25mm, 6 wells
MC-B29	For 50ml centrifuge tube, 6 wells
MC-B0.2H	(1/2) half block for 0.2ml tube, 40 wells ( or 0.2ml PCR strip tube for 8 wells x 5 ) One Ultimate Dry Bath Incubator can insert 2ea of half block
MC-B0.5H	(1/2) half block for 0.5ml tube, 15 wells One Ultimate Dry Bath Incubator can insert 2ea of half block
MC-B1.5H	(1/2) half block for 1.5 or 2ml tube, 15 wells One Ultimate Dry Bath Incubator can insert 2ea of half block

\* For a complete list of accessories, please refer to [Page 84-87](#)

# Dry Bath Block & Beads

## Metallic Thermal Beads Mini Dry Bath Blocks Dry Bath Blocks Ultimate Dry Bath Blocks

### For Beads

Major Science offers you the Metallic Thermal Beads as an alternative to the dry bath aluminum blocks. The beads are dry metallic thermal alloy designed to replace water in a water bath and ice in an ice bucket. Not only our metallic thermal beads provide you far less conductive to contamination than a water bath when using in a dry bath incubator, the beads are also recyclable which brings you convenience to eliminate the routine use of harmful germicides and are more energy efficient than water. The metallic thermal beads also help to eliminate maintenance tasks such as emptying, cleaning, monitoring, and refilling the water bath to give you a more hassle-free environment in the lab. We specifically pack the beads in a standard pack for your ease of ordering.

### For Blocks

The Dry Bath Blocks are designed for the MS Thermoblock Dry Bath Incubator. The precisely machined aluminum alloy blocks deliver efficient heat transfer and are suitable for microplate and various sizes of test tubes and centrifuge tubes ranging from 0.2ml to 50ml. In addition to the standard blocks, customized blocks are also available according to user's requirement.



beads

### Thermal Beads Specifications

Cat. No.	Beads
Properties	Metal composition
	Moisture and gas impermeable
	High thermal conductivity
	Smooth, rounded surface
Working Temperature Range	-80°C to 180°C
Size	Diameter 5-8mm, Height 1-2mm
Weight	3.6lbs per liter
Environment	Recyclable
	Non-toxic, non-vaporizing material
	No daily requirement for biocide use – no gray water
	Improves energy efficiency of standard water baths by over 50%

### Ordering Information

Cat. No.	Product Description
MD-MINI-BD00	Metallic thermal beads for Mini dry bath incubator, for MD-MINI, 170g (Beads only)
MD-BD00	Metallic thermal beads for Genius and Elite dry bath incubator, for MD-01N and EL-01, 700g (Beads only)
MC-BD00	Metallic thermal beads for Ultimate dry bath incubator, for MC-01N, 900g (Beads only)



Product may be used up to 300°C without loss in thermal performance, but product fluidity may be reduced.

### Features (for beads)

- Fully compatible with MS Dry Bath Incubators
- Keeps your equipment dry and protected from water-borne microbial contaminants
- 50% more energy efficient than water bath
- High efficiency to warm, thaw, incubate and chill samples at constant temperatures
- Eliminates the hassle of emptying, cleaning and refilling water baths or changing blocks
- Support all shapes of labwares
- Stays clean and disinfects easily



### Features (for blocks)

- Precisely CNC machined aluminum alloy blocks
- R -curve edged block design
- Through Sand Blast Anodizing Surface treatment, it ensure a nice & smooth surface block with a longer durability
- Laser marked on the selected blocks





## Aluminum alloy blocks Specifications

Cat. No.	Mini Dry Bath Blocks	Dry Bath Blocks	Ultimate Dry Bath Blocks
Photo			
Used For	MD Mini <a href="#">Page 75</a> , MC-0203 <a href="#">Page 76</a>	EL series <a href="#">Page 80</a> , MD series <a href="#">Page 78</a>	MC-01 series <a href="#">Page 82</a>
Block Lifter	included		
Product Description	The Mini Dry Bath Blocks are designed for both mini heating or cooling dry bath incubators. The precisely machined aluminum alloy blocks deliver efficient heat transfer and are suitable for PCR tubes in strip and various size of test tubes and centrifuge tubes ranging from 0.2ml to 50ml.	The Dry Bath Blocks are designed for the Elite Dry Bath Incubator and the Genius Dry Bath Incubator. The precisely machined aluminum alloy blocks deliver efficient heat transfer and are suitable for microplate and various size of test tubes and centrifuge tubes ranging from 0.2ml to 50ml.	The Ultimate Dry Bath Blocks are designed for the Ultimate Dry Bath Incubators. The precisely-machined aluminum alloy blocks, which are suitable for microplate and different sizes of test tubes and centrifuge tubes ranging from 0.2ml to 50ml, deliver efficient heating and cooling performance. In addition to the standard blocks, customized blocks are also available to broaden the applications of the Ultimate Dry Bath Incubator. MC Blocks are designed for Ultimate plus Dry Bath Incubator to provide even more efficient heating and cooling speed. Two standard block modes and customized blocks are available.
Block Material	Aluminum alloy		
Dimension (WxLxH)	Approx. 1.9"x2.8"x1.3" (47x71x32mm) for MD-MINI-B01/02/05/06/07  Approx. 1.9"x2.8"x3" (47x71x75mm) for MD-MINI-B03/04	Approx. 3.4"x5"x2.5" (87x128x62.3mm) for MD-MP01-S  Approx. 4.1"x6.2"x2" (104x158x50mm) for MD-MP01-D/ MD-MP02-D  Approx. 3.4"x5"x2.7" (87x128x69.5mm) for MD-MP02-S  Approx. 3.1"x4.1"x2" (79x104x50mm) for standard blocks	Approx. 3.5"x5.1"x1.8" (89x129x46mm) for standard blocks  Approx. 2.5"x3.5"x1.8" (64.5x89x46mm) for MC-B0.2H/0.5H/1.5H  Approx. 3.5"x5.1"x1.2" (89x129x30mm) for MC-BS0.2+0.5/0.5+1.5
Weight	Approx. 0.5lb (0.24kg) for MD-MINI-B01/02/05/06/07  Approx. 1.0lb (0.46kg) for MD-MINI-B03/04	N/A	
Block Lifter Well	Yes		
Thermometer Well	Yes	Yes (except microplate blocks)	

\*Customized blocks available.

### Laser marked on the selected blocks

#### Flow chart for customization process:

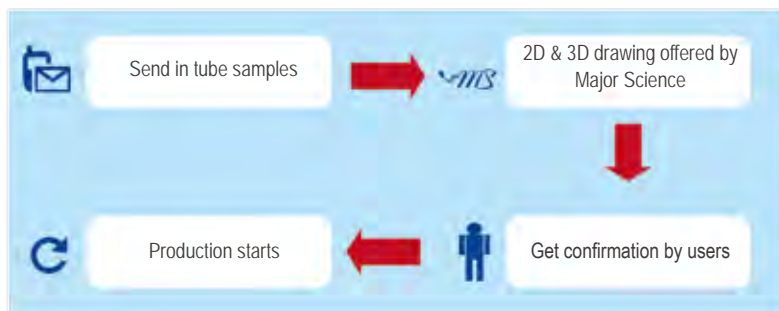

## Ordering Information

Cat. No.		Product Description
Mini Dry Bath Blocks	MD-MINI-B01	For 0.2ml tube (PCR strip tube), 32 wells, Ø6.35mm, depth 17mm, (WxLxH) 47x71x32mm
	MD-MINI-B02	For 1.5ml tube, 12 wells, Ø10.88mm, depth 30mm, (WxLxH) 47x71x32mm
	MD-MINI-B03	For 15ml tube, 6 wells, Ø17.3mm, depth 70mm, (WxLxH) 47x71x75mm
	MD-MINI-B04	For 50ml tube, 2 wells, Ø29.0mm, depth 70mm, (WxLxH) 47x71x75mm
	MD-MINI-B05	For 0.5ml tube, 12 wells, Ø7.9mm, depth 25mm, (WxLxH) 47x71x32mm
	MD-MINI-B06	For 2.0ml or 1.5ml tube, 12 wells, Ø11.0mm, depth 30mm, (WxLxH) 47x71x32mm
	MD-MINI-B07	For 2.0ml or 1.5ml tube, 12 wells, Ø11.0mm, depth 30mm, (WxLxH) 47x71x32mm
	MS-BL95-E	Block Lifter, 95mm length with E-type retaining rings
Dry Bath Blocks	MD-MP01-S	For microplate; titerplate (Plain Block for Single Block unit only)
	MD-MP01-D	For microplate; titerplate (Dual Block unit only)
	MD-MP02-S	For 96 wells deep microplate or PCR plate ( for Single Block unit only)
	MD-MP02-D	For 96 wells deep microplate or PCR plate ( for Dual Block unit only)
	MD-B0.2	For 0.2ml tube, 64 wells (or 0.2ml PCR strip tube for 8 wells x 8)
	MD-B0.5	For 0.5ml tube, 20 wells
	MD-B1.5	For 1.5ml or 2.0ml tube, 20 wells
	MD-B1.5V	For 1.5ml or 2.0ml V-shaped tube, 20 wells
	MD-B0.5+1.5	Combination: for 0.5ml tube, 12 wells; and for 1.5ml tube, 12 wells (on the same side)
	MD-B0.5/1.5	One side for 1.5 or 2.0ml tube, 20 wells and another side for 0.5ml tube, 30 wells (on the opposite side)
	MD-B13	Well size 13mm, 20 wells
	MD-B17	For 15ml centrifuge tube, 12 wells
	MD-B20	Well size 20mm, 12 wells
	MD-B25	Well size 25mm, 6 wells
	MD-B29	For 50ml centrifuge tube, 4 wells
	MD-BD01	Single bead MD dry bath block, (WxLxH) 79x104x76mm
	MD-BD02	Dual bead MD dry bath block, (WxLxH) 104x158x76mm
MS-BL95-E	Block Lifter, 95mm length with E-type retaining rings	
Ultimate Dry Bath Blocks	MC-MP01	For Microplate; titerplate (Plain Block)
	MC-MP02	For 96 wells deep microplate or PCR plate
	MC-B0.5	For 0.5ml, 30 wells
	MC-B1.5	For 1.5 or 2.0ml, 30 wells
	MC-B0.5+1.5	Combination: for 1.5ml or 2.0ml tube, 15 wells and 0.5ml tube, 15 wells (on the same side)
	MC-B0.2+0.5+1.5	Combination: 0.2ml tube (or strip tube for 8 wells ), 24 wells; 1.5ml or 2.0ml tube, 10 wells and 0.5ml tube, 10 wells (on the same side)
	MC-B13	Well size 13mm, 30 wells
	MC-B17	For 15ml centrifuge tube, 15 wells
	MC-B20	Well size 20mm, 15 wells
	MC-B25	Well size 25mm, 6 wells
	MC-B29	For 50ml centrifuge tube, 6 wells
	MC-B0.2H	(1/2) half block for 0.2ml tube, 40 wells ( or 0.2ml PCR strip tube for 8 wells x 5) One Ultimate Dry Bath Incubator can insert 2ea of half block
	MC-B0.5H	(1/2) half block for 0.5ml tube, 15 wells One Ultimate Dry Bath Incubator can insert 2ea of half block
	MC-B1.5H	(1/2) half block for 1.5 or 2ml tube, 15 wells One Ultimate Dry Bath Incubator can insert 2ea of half block
	MC-BS0.2+0.5	Combination: 0.2ml tube, 36 wells; 0.5ml, 20 wells
	MC-BS0.5+1.5	Combination: 0.5ml tube, 18 wells; 1.5ml, 14 wells
	MC-BD	Ultimate bead bath block, (WxLxH) 90x127x76mm
	MS-BL95-E	Block Lifter, 95mm length with E-type retaining rings

MS Thermoblock Dry Bath Incubator

Mini Dry Bath Blocks

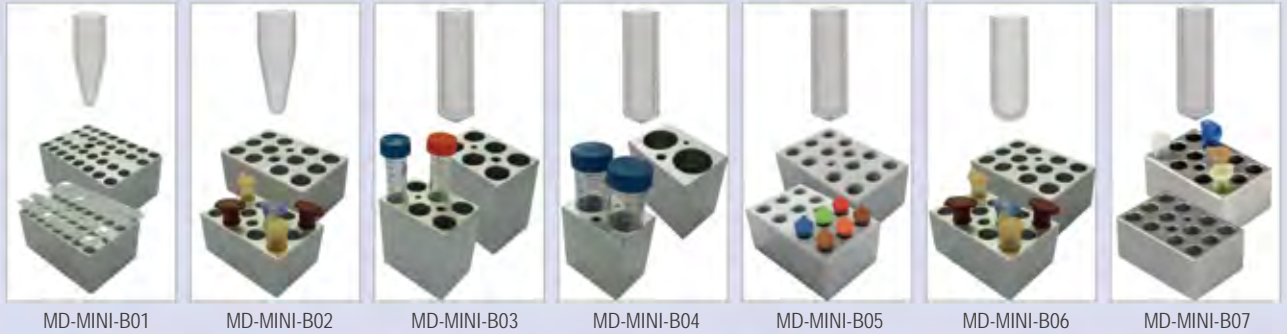

Dry Bath Blocks

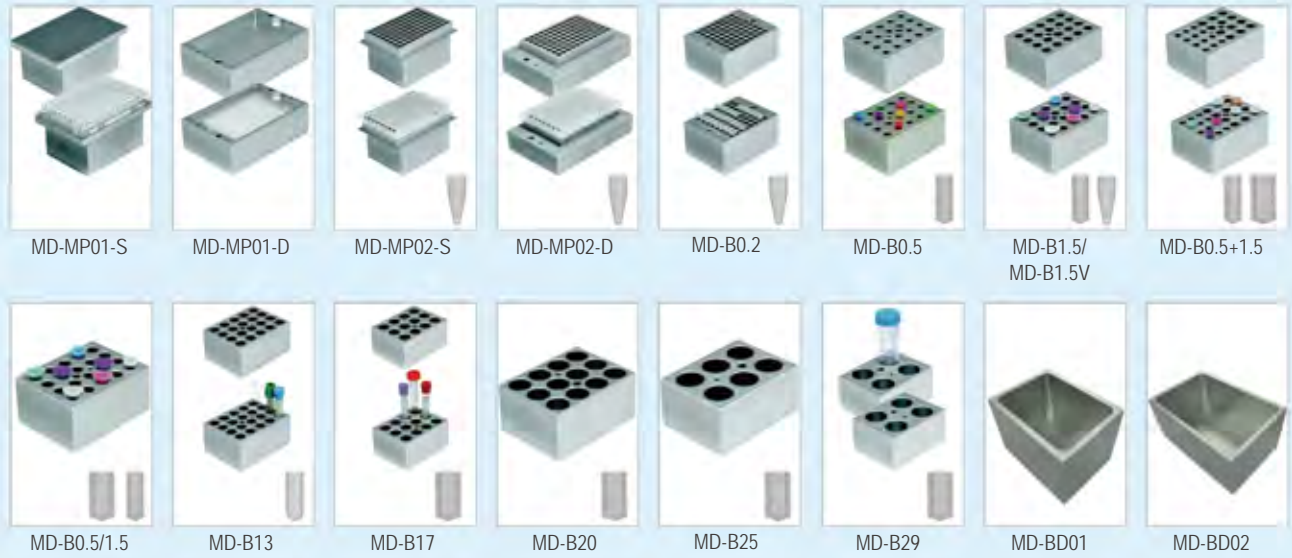

Ultimate Dry Bath Blocks

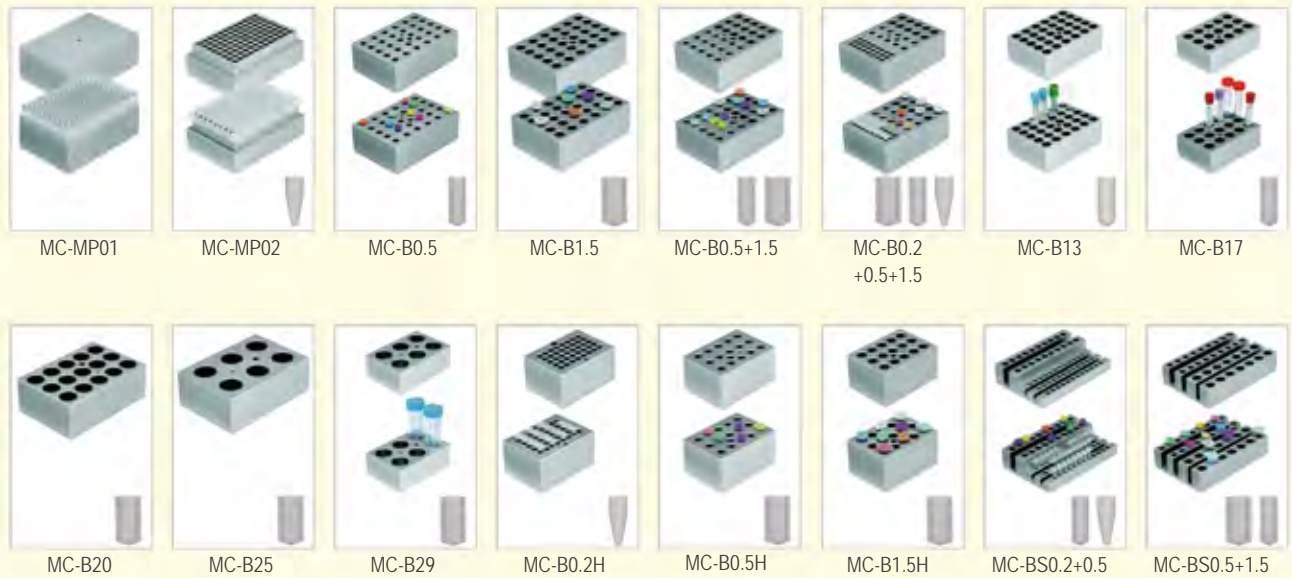



# MS Mini Incubator

## MO-MINI

Major Science's Mini Incubator is designed for personal using and small laboratories, saving much of space. The unit features a broad temperature range to meet a variety of microbiology or hematology applications.

It is compact and economically priced, yet offers unique features not typically found in other incubators. The housing is all corrosion resistant metal, so is the door frame. The glass window of the door offers full visibility to the interior. One stainless steel shelf is included, and can be adjusted to two different levels - additional shelves can be purchased to increase storage capacity. The color touch panel presents vivid and intuitive user interface and the backlit LED ensures enough brightness even in dark environment.

The heating structure incorporated in MS Mini Incubator performs evenly heating and precise temperature control. The microprocessor ensures temperature stability within the chamber. A thermometer port on the top of the unit allows the user to monitor temperatures. In addition, a designed spare port is on the rear of the chamber which allows for an electrical cord to be routed out if needed. Optional function control software allows the Mini Incubator to perform real-time data recording through a PC.



### Specification

Cat. No.	MO-MINI
Display	LCD
Temperature Range	Ambient +5° to 70°C
Capacity	17L
Exterior Dimension (WxLxH)	Approx. 12.2"x12"x15" (310x306x380mm)
Interior Dimension(WxLxH)	Approx. 10.3"x10"x10" (261x255x255mm)
Weight	Approx. 28.7 (13kg)
Power	100-240V~, 50/60Hz, 2A
Material	Corrosion resistant metal
PC Connection	USB

### Ordering Information

Cat. No	Product Description
MO-MINI	MS Mini Incubator with one stainless steel shelf

### Accessories

Cat. No	Product Description
MO-SH2524	250x240mm stainless steel shelf for MS Mini Incubator
MO-MINI-SW	Functional control software for MS Mini Incubator, including a USB cable

### Features

- Ideal for microbiology or hematology applications
- Corrosion resistant metal housing
- Door with large viewing area
- Backlit colored touched panel
- One stainless steel shelf is included
- Function control software available

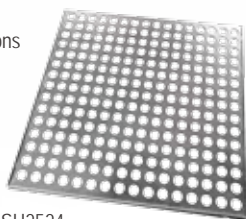

MO-SH2524



# MS Oven

## MO-A01

Major Science's Oven incubator features a broad thermostatic control range and precise temperature uniformity to fulfill a variety of cell culturing and hematology applications. The compact size and stackable design save valuable lab space and maximize productivity. The built-in color touch screen provides hassle-free system operation and instance glance over experiments. With implemented safety features, the powerful MS Oven incubators assure a safe environment to the user as well as samples.

### Features

- Large touch screen: 3.5" color display
- Temperature uniformity and accuracy:  $\pm 0.2^{\circ}\text{C}$  at  $37^{\circ}\text{C}$
- Broad temperature control range: ambient  $+5^{\circ}\text{C}$  to  $85^{\circ}\text{C}$
- User temperature calibration
- Safety door switch
- Timer with alarm function
- Power failure auto recovery
- Sturdy, stackable construction



MO-A01

# MS Hybridization Oven

## MO-AOR

## MO-ARK

MS Hybridization Oven series is the advanced and newly renovated version of MS Oven. Besides all the advantages that previous generation has, the two models of MS Hybridization Oven are designed to equip with built-in rotisserie function. The difference of the two models lies in the shaking motion. MO-AOR is embedded with orbital shaking platform while MO-ARK provides an optional rocking one (MO-SEESAW). MS Hybridization Oven is ideal for nucleic acid hybridization and incubation such as Southern, Northern, and Western blot. Full accessories are also available upon request to meet different applications.

### Features

- Built-in rotisserie function
- Orbital/ Rocking shaking motion
- Large touch screen: 3.5" color display
- Temperature uniformity and accuracy:  $\pm 0.2^{\circ}\text{C}$  at  $37^{\circ}\text{C}$
- Broad temperature control range: ambient  $+5^{\circ}\text{C}$  to  $85^{\circ}\text{C}$
- User temperature calibration
- Safety door switch
- Timer with alarm function
- Power failure auto recovery
- Sturdy, stackable construction



MO-AOR



MO-ARK



### Model Selection Guide



Cat. No.	MO-A01	MO-AOR	MO-ARK
Rotisserie Function	N/A	Yes	Yes
Rotisserie Speed / Inc.	N/A	5-100rpm / 1rpm	5-100rpm / 1rpm
Shaker Motion	N/A	Orbital clockwise / counterclockwise	Rocking*
Shaker Speed	N/A	0-200rpm	5-100rpm

\* To perform rocking motion, an optional accessories, MO-SEESAW, is required.

Max. set of flask holder		
Flask	MO-AOR	MO-SEESAW
50ml	8	5
125ml	8	5
250ml	5	5
500ml	2	1



Stackable design



## Specification

Cat. No.	MO-A01	MO-AOR	MO-ARK
Display	3.5" 64K color TFT display		
Controller	32-bits Microprocessor		
Control Interface	Touch screen & graphical interface		
Rotisserie Function	N/A	Yes	Yes
Rotisserie Speed / Inc.	N/A	5 - 100rpm / 1rpm	5 - 100rpm / 1rpm
Timer	9999 (min) with alarm / Continuous		
Shaker Motion	N/A	Orbital clockwise / counterclockwise	Rocking*
Shaker Speed	N/A	0 - 200rpm	5 - 100rpm
Temperature Control Range	Ambient +5°C to 85°C		
Temperature Increment	0.1°C		
Temperature Uniformity	± 0.2°C at 37°C		
Temperature Accuracy	± 0.2°C at 37°C		
User Temperature Calibration	Yes		
Inner Chamber Dimensions (WxLxH)	Approx. 13.4"x8.9"x10.2" (340x225x260mm)		
Inner Chamber Volume	Approx. 5.28gal (20L)		
Dimension (WxLxH)	Approx. 17.4"x18.2"x17.8" (442x462x452mm)		
Platform (WxL)	N/A	Approx. 10.6"x7.9" (270x200mm)	Approx. 10.6"x7.9" (270x200mm)
Data Logging	RS-232		
Weight	Approx. 52.9lb (24kg)	Approx. 63.9lb (29kg)	Approx. 63.9lb (29kg)
Rated Voltage	110 / 220V - 50 / 60Hz (Selectable)		
Construction	Painted iron metal with ABS front door		
Safety Device	Safety door switch		
	Thermal safety switch		
	Auto shut off upon fan failure		
	Power failure auto recovery		

\* To perform rocking motion on optional accessories, MO-SEESAW is required.

## Ordering Information

Cat. No	Product Description
MO-A01	MS Oven with 2 layers of stainless steel mesh plates and 8 plate holders
MO-AOR	MS Hybridization/Orbital Shaking Oven (without rotisserie), 110 / 220V-
MO-ARK	MS Hybridization Oven (w/o rotisserie & rocking shaker platform), 110 / 220V-

## Accessories

Cat. No	Product Description
MO-01-PF	1 layer of stainless steel mesh plate with 4 plate holders
MO-HY-8RT	40mm tube rotisserie for 8 tubes
MO-HY-16RT	50ml conical tube rotisserie for 16 tubes
MO-HY-24RT	15ml conical tube rotisserie for 24 tubes
MO-P2320	Additional 230x200mm platform for orbital and reciprocal shaker (with 4 of 100mm pillars)
MO-SEESAW	Rocking Shaker platform for MO-ARK
SI-200-08	Flask Holder, 50ml
SI-200-09	Flask Holder, 125ml
SI-200-10	Flask Holder, 250ml
SI-200-11	Flask Holder, 500ml
MO-BT40x150	Glass tube 40x150mm (diameter x length)
MO-BT40x200	Glass tube 40x200mm (diameter x length)
MO-BT40x300	Glass tube 40x300mm (diameter x length)

• Various accessories available

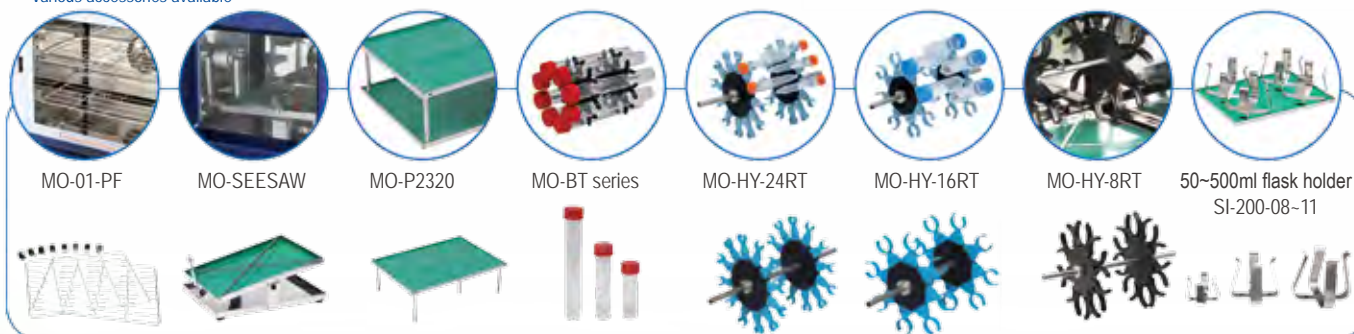

Touch screen & graphical control interface



# MS Orbital Shaker MS Reciprocal Shaker MS Rocking Shaker

MS-NOR-30 / MS-NOR-3001  
MS-NRC-30 / MS-NRC-3001  
MS-NRK-30 / MS-NRK-3001

Three different shaking motions of MS Shaker series is provided for many general purpose shaking application in chemical and life sciences laboratories. The Orbital Shaker digitally controls clockwise and/or counter-clockwise orbits to create superb mixing efficiency. The Reciprocal Shaker features a horizontal (left to right) linear action to provide gentle to vigorous shaking motion. The Rocking Shaker provides a "12-degree" tilted angle rocking motion for variety of applications. All three models provides continuous or timed operation with integral electronic timer, LED display, audible signal for automatic switch-off timed control, interchangeable/stacking platforms. Reciprocal shaker can hold up to 15kg of weight whereas rocking and orbital shaker can hold up to 10kg(orbital) and 8kg(rocking), respectively.

For Anti-moisture model

The MS Anti-moisture Shaker series offers the same capabilities as our original MS shaker series with moisture protection coating. The moisture protection allows you to operate the shaker in cold-room or low temperature environment. An anti-moisture coating is applied on the electrical structure to minimize and prevent the forming of condensation when operating in & out of the cold room. Standard features and accessories from the MS shaker series apply to all three different models.



Heavy loading capacity (ex. MS-NRC-30)

## Features

- Continuous one way orbital shaking or two ways clockwise/ counter-clockwise orbital shaking
- Continuous or timed operation with auto shut-off
- Variable shaking speed up to 200rpm for MS-NOR-30
- Variety of accessories available
- Max. 17.6lb (8kg) loading capacity for MS-NRK-30
- Max. 22.0lb (10kg) loading capacity for MS-NOR-30
- Max. 33lb (15kg) loading capacity for MS-NRC-30
- Special anti-moisture coating allows smooth operation in cold room environment or CO<sub>2</sub> incubation
- Optional 300x300mm platform available for your selection.

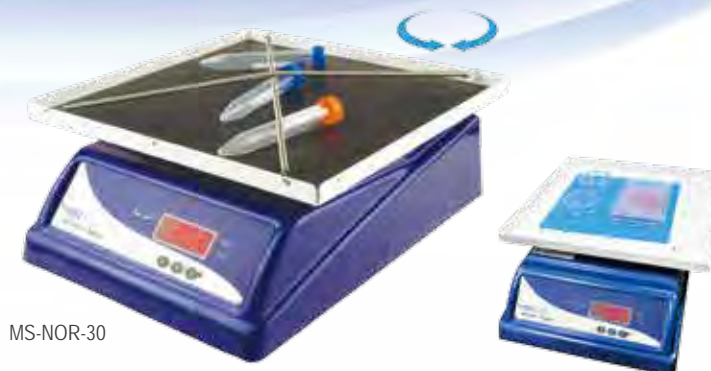

MS-NOR-30

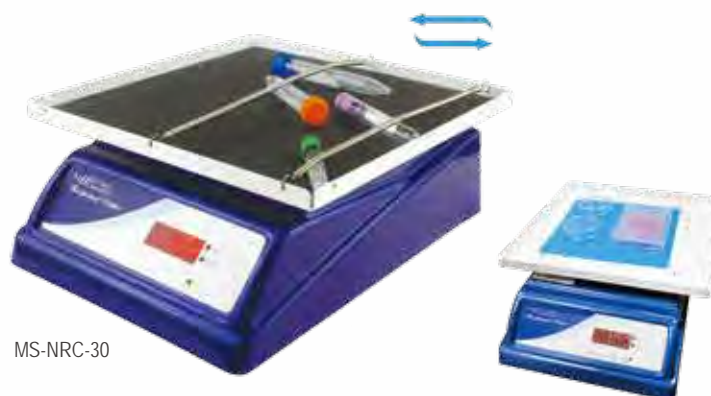

MS-NRC-30



MS-NRK-30

FC CE



MS Orbital Shaker  
MS-NOR-30



MS Reciprocal Shaker  
MS-NRC-30



MS Rocking Shaker  
MS-NRK-30

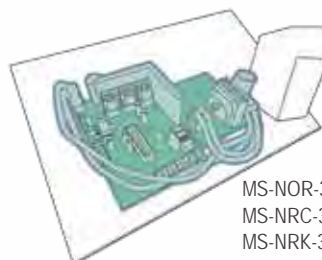

Special coating allows anti-moisture for cold room operation

## Platform capability of Flask Holders

Flask	Max. set of flask holder	
	MS-NOR-30	MS-NRC-30 MS-NRK-30
50ml	13	13
125ml	12	12
250ml	9	9
500ml	5	5
1000ml	4	4
2000ml	1	2

\*When operating with second-tier platform, max. loading capacity may change.

## Specification

Cat. No.	MS-NOR-30 (MS-NOR-3001**)	MS-NRC-30 (MS-NRC-3001**)	MS-NRK-30 (MS-NRK-3001**)
Motion	Orbital	Reciprocal	Rocking
Moving Feature	Orbital action in one direction or two directions	Steady moving motion at 5rpm	
Bi-directional Shaking	0.1 - 10 circle / 0.1 circular increment	N / A	
Maximum Tilt Angle	N / A		12°
Maximum Stroke Length	20mm		N / A
Controller	Digital microprocessor controller		
Speed/Inc.	0 - 200rpm / 1rpm	5 - 100rpm / 1rpm	
Timer	9999 (min) with alarm / Continuous		
Loading Capacity	22.0lb (10kg)	33.0lb (15kg)	17.6lb (8kg)
Motor	Stepping motor	DC brushless type	
Operating Temperature	Ambient to 40°C		
Platform Dimension (WxL)	Approx. 1.2"x1.2" (300x300mm)		
Platform Material	Painted iron metal		
Stacking Platform	Yes		
Dimension (WxLxH)	Approx. 11.8"x12.2"x5.1" (300x310x130mm)		
Material	ABS and Painted iron metal		
Weight	Approx. 15.4lb (7.0kg)		
Rated Voltage	110V / 220V- selectable; 50/60Hz; 0.63A		

\*\* Anti-moisture coating

## Ordering Information

Cat. No.	Product Description
MS-NOR-30	MS Orbital Shaker with 300x300mm platform and flat non-slip rubber mat, 110V/ 220V~
MS-NOR-3001	MS Orbital anti-moistured shaker with 300x300mm platform and flat non-slip rubber mat, 110V/220V~
MS-NRC-30	MS Reciprocal Shaker with 300x300mm platform and flat non-slip rubber mat, 110V /220V~
MS-NRC-3001	MS Reciprocal anti-moistured shaker with 300x300mm platform and flat non-slip rubber mat, 110V/220V~
MS-NRK-30	MS Rocking Shaker with 300x300mm platform and flat non-slip rubber mat, 110V /220V~
MS-NRK-3001	MS Rocking anti-moistured shaker with 300x300mm platform and flat non-slip rubber mat, 110V/220V~

## Accessories

Cat. No.	Product Description
MW-SP	Strip springs (pack of 2), 265mm
MS-P3030	Additional 300x300mm platform with attachable 100mm pillars 8pcs and flat non-slip rubber mat
MS-DIMPLED-30	300x300mm dimpled mat
MS-FLAT-30	Non-slip rubber mat 300x300mm
MS-UP-30	Universal adjustable platform, 300x300mm (Maximum capacity: 2x2L flasks)
PPL-04-SI-SI-200-3	Sticky Pad 200x200mm
SI-200-08	Flask Holder, 50ml
SI-200-09	Flask Holder, 125ml
SI-200-10	Flask Holder, 250ml
SI-200-11	Flask Holder, 500ml
SI-200-12	Flask Holder, 1000ml
SI-200-13	Flask Holder, 2000ml



MW-SP



MS-P3030



MS-DIMPLED-30



MS-FLAT-30



MS-UP-30

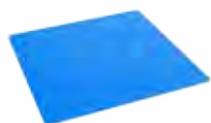

PPL-04-SI-SI-200-3



50~2000ml flask holder  
SI-200-08~13

# 10L / 20L Stirring Water Bath

## SWB series

The MS Stirring Water Bath series packed with built-in thermostatic baths are innovative product line to provide precise temperature control and excellent mixing performance for a wide range of laboratory applications. The built-in stirring mechanism not only provides outstanding temperature uniformity, but also applies a stirring mixture function. The 10L or 20L stainless steel tank can operate flask(s) containing a moderate amount of solution simultaneously. Single stirring mechanism model and multi-stirring models are available for your preference.



SWB-10L

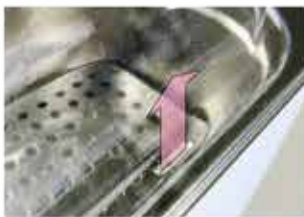

Built-in magnetic stirring mechanism





Max. capability: 6 sets of 250ml flasks  
4 sets of 500ml flasks



SWB-20L

The size of different brand bottle may vary slightly. Please refer the following table as reference only.

Compatible Bottle of SWB -20L -3

	≤500ml	1L	2L
	3	3	2 (position 1 & position 3)
	3	2 (position 1 & position 3)	2 (position 1 & position 3)*
	3	3	2 (position 1 & position 3)

\*\*Teflon Stir Bar, Cylindrical, L≤60 mm.

\*When 2L Erlenmeyerflask is applied, it may be too high for the lid of water bath to put on.

### Features

- Microprocessor control with digital performance for precise, accurate control
- Built-in magnetic stirring mechanism for water agitation, water temperature uniformity and medium solution mixing
- Stirring speed control
- LCD screen shows temperature and timer simultaneously
- User temperature calibration
- Safety device: warning indication on screen to avoid overheating and automatic shut down
- Multiple stirring mechanism capability
- Data Logging software available



Max. capability: 15 sets of 250ml flasks  
8 sets of 500ml flasks







Concave lid design allows condensation flow back to the tank.



Side opening of the lid to allow minimum evaporation while maintaining water bath temperature.



Water circulation function

-  Magnetic agitator
-  Stir bar

## Specifications

Cat. No.	SWB-10L-1	SWB-10L-2	SWB-20L-1	SWB-20L-3
Number Of Stirring Mechanisms	1	2	1	3
Stirring Speed	400-1500rpm (measured by percentage)			
Bath Capacity	Approx. 2.64gal (10L)		Approx. 5.28gal (20L)	
Water Circulation Function	Yes			
Display	LCD			
Heating Power	600W		800W	
Controller	Digital microprocessor controller			
Bath Temperature	5 °C above ambient to 99 °C			
Temperature Increment	0.1°C			
Temperature Accuracy	±0.2 °C at 37 °C			
Temperature Calibration	Yes			
Timer	99 (hr): 59 (min) / Continuous			
Safety Device	Warning indication on screen with alarm and automatic shut down			
Operating Temperature	Ambient to 40 °C			
Bath Tank Material	304 stainless steel			
Bath Inner Dimension (WxLxH)	Approx. 9.5"x11.8"x5.9" (240x300x150mm)		Approx. 11.8"x19.7"x5.9" (300x500x150mm)	
Dimension (WxLxH) (without lid)	Approx. 10"x14"x9.5" (255x355x240mm)		Approx. 13"x21.3"x9.5" (330x540x240mm)	
Rear Drainage Port	N / A		Yes	
Material	Painted iron metal			
Lid Material	Polycarbonate with stainless steel handle			
Communication Port	RS232			
Weight	Approx. 19.8lb (9kg)		Approx. 30.9lb (14kg)	
Rated Voltage	110V / 220V~			

## Ordering Information



Cat. No.	Product Description
SWB-10L-1-110 / 220	10L Stirring Water Bath with 1 built-in stirring mechanism, lid included
SWB-10L-2-110 / 220	10L Stirring Water Bath with 2 built-in stirring mechanism, lid included
SWB-20L-1-110 / 220	20L Stirring Water Bath with 1 built-in stirring mechanism, lid included
SWB-20L-3-110 / 220	20L Stirring Water Bath with 3 built-in stirring mechanism, lid included

## Accessories

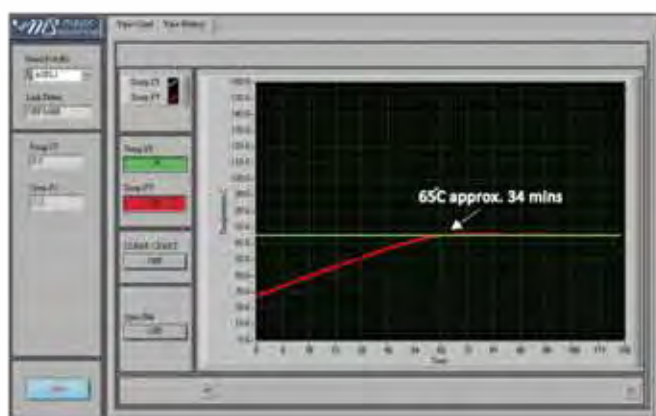
Cat. No.	Product Description
SWB-LID10	Transparent lid for 10L Stirring Water Bath
SWB-LID20	Transparent lid for 20L Stirring Water Bath
SWB-RS232	RS 232 cable for data logging
SWB-DLSW	Data Logging software package
SWB-DLSW-R	Data Logging software package, include a RS 232 cable



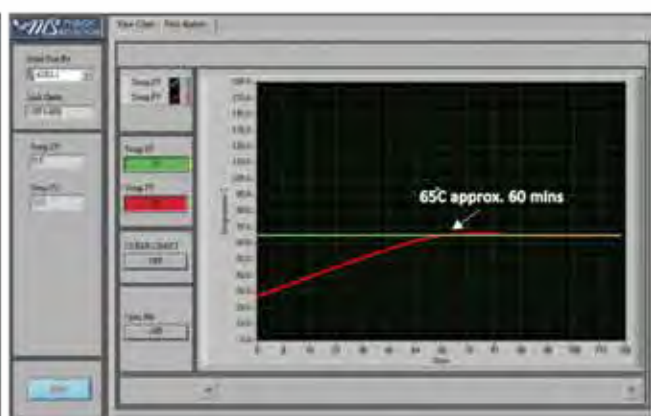

SWB-10L series

-  Temp. set value : 65 °C
-  Initial temp. value : 17 °C
- Water volume : 5 liters
- Process time : Approx. 34mins



SWB-20L series

-  Temp. set value : 65 °C
-  Initial temp. value : 27 °C
- Water volume : 12 liters
- Process time : Approx. 60mins

## Peristaltic Pump

The MS Peristaltic Pump series offers several digitally-controlled versions of the peristaltic pump for a variety of applications, which provide high accuracy of rpm performance. The MU-D series is the single pump head version, controlled by a microprocessor. The MFU series features a dual or tetrad pump heads, which perfectly fulfill high-volume demands with multi-tubing purposes.

### Peristaltic Pump

#### ▣ Peristaltic Pump

96-97

Digital Peristaltic Pump

Dual and Tetrad Peristaltic Pump



\*All images are for reference only, actual products might differ from the images.

\*Please visit our website at [www.majorsci.com](http://www.majorsci.com) for more product selection and detailed information.

\*Technical specification subject to change without notice.

# Digital Peristaltic Pump Dual and Tetrad Peristaltic Pump



## MU-D series MFU series

### For MU-D series

MU-D Peristaltic Pump series is ideal for a variety of applications, which include filtration, circulation, sampling, chemical spraying, dispensing, transferring, feeding and filling. The easy-to-use pump head design accommodate several different silicon tubing sizes. This provides a great flexibility for a wide range of flow rates to be utilized when connecting with different sizes of tubings.

The MU-D series is also reversible providing better convenience and flexibility to the user. The digital control provides high accurate rpm performance.

MU-D01 pump is a digital controlled mode with a solid 50W brushless motor, and MU-D02 is designed with a higher horsepower, 100W for higher volume demands required.

MU-D03 pump is the most powerful pump in this series which packs with powerful pump head, allows the flow rate to up to 3,272ml/min with thicker tubing (1.6mm). Select the appropriate model for your lab with economical yet powerful enough peristaltic pump.



MU-D01/MU-D02

MU-D03



(Only MU-D01)



Easy load pump head



Expandable pump head

### For MFU series

The Dual and Tetrad Peristaltic Pump are equipped with two and four peristaltic pumps respectively, and can be controlled separately. Digital microprocessor provides precise speed control; individual timer and alarm function are equipped with all standard pumps. The Dual and Tetrad Peristaltic Pump can be used for various applications such as filtration, circulation, sampling, chemical spraying, dispensing transferring, feeding and filling. The easy-to-use pump head design is also conveniently reversible for purging, allowing further flexibility in any experiment.



MFU-01



MFU-02



Easy load pump head

### Features:(for MU-D series)

- Digital microprocessor control for precise speed control
- Compact size provides high portability
- High quality Masterflex and Watson Marlow easy load pump head
- Reversible for purging purposes
- Flow rate range from 1.2 to 1,140ml/min for MU-D01
- Flow rate range from 0.3 to 2,280ml/min for MU-D02
- Flow rate range from 8 to 3,272ml/min for MU-D03
- 2-step programmable operation mode available

### Features:(for MFU series)

- Compact size provides high portability
- Precise digital control for individual pump head
- High quality Verderflex Easy Load pump head
- Two or four pump head models available
- Allow individual control for each pump head
- Wide applications
- Reversible for purging purposes usage
- 2-step programmable operation mode available
- Expandable pump head for wider range of applications



## Specifications

Cat. No	MU-D01	MU-D02	MU-D03	MFU-01	MFU-02
Controller	Digital microprocessor controller				
Motor	Brushless motor			Stepping motor	
Power	50W	100W			
Pump Speed / Increment	20 - 300rpm / 1rpm	5 - 600rpm / 1rpm	20 - 300rpm / 1rpm	1 - 100rpm / 1rpm	
Max. Pump Speed	300rpm	600rpm	300rpm	100rpm	
Flow Range **	1.2 - 1,140ml/min	0.3 - 2,280ml/min	8 - 3,272ml/min	0.08 - 375ml/min	
Number Of Rollers	3		2	3	
Number Of Peristaltic Pumps	1(max. 2)		1	2	4
Operating Temperature	Ambient to 40 °C				
Dimension (WxLxH)	Approx. 7.9"x13.4"x5.1" (200x340x130mm)		Approx. 9.5"x13.3"x 6.6" (240x338x167mm)	Approx. 10.4"x13.4"x7.1" (265x340x180mm)	Approx. 12.4"x13.4"x7.1" (315x340x180mm)
Material	Painted iron metal				
Weight	Approx. 12.5lb ( 5.7kg )		Approx. 13.4lb (6.2kg)	Approx. 15.4lb (7kg)	Approx. 24.9lb (11.3kg)
Rated Voltage	110V/220V~	100V-240V~	100V-240V~	110V-240V~	
Program	2-step Program (running & ceasing); Max. of timer: 99 (hr) : 59 (min) : 59 (sec)				
Auto Resume Function	Yes			N /A	

\*\*The flow range is subject to the silicone tube that used. Please see Silicone tubing specifications table for reference.

## Ordering Information

Cat. No	Product Description
MU-D01	Digital Peristaltic Pump, 110 / 220V~
MU-D02	Superior Digital Peristaltic Pump, 100V-240V~
MU-D03	Supreme Digital Peristaltic Pump, 100V-240V~
MFU-01	Dual Peristaltic Pump
MFU-02	Tetrad Peristaltic pump
PWI-FS-05-00000000	Digital Peristaltic Pump connection cable for FS-05
PWI-FS-06-00000000	Digital Peristaltic Pump connection cable for FS-06, FS-07

## Accessories

Cat. No	Product Description
MU-PU1	Easy Load pump head for MU-D01 / MU-D02
MU-S13	Silicon tube I.D. 0.03 inch (0.8mm), 25ft
MU-S14	Silicon tube I.D. 0.06 inch (1.6mm), 25ft
MU-S16	Silicon tube I.D. 0.12 inch (3.1mm), 25ft
MU-S25	Silicon tube I.D. 0.19 inch (4.8mm), 25ft
MU-S17	Silicon tube I.D. 0.25 inch (6.4mm), 25ft
MU-S18	Silicon tube I.D. 0.31 inch (7.9mm), 25ft (MU-D series only)

## Tubing Information

Silicon Tubing Specifications						
Cat. No.	MU-S13	MU-S14	MU-S16	MU-S25	MU-S17	MU-S18
Inner Diameter Inches. (mm)	0.03(0.8)	0.06(1.6)	0.12(3.1)	0.19(4.8)	0.25(6.4)	0.31(7.9)
Hose Barb Size Inches. (mm)	1/16(1.6)	1/16(1.6)	1/8(3.2)	3/16(4.8)	1/4(6.4)	3/8(9.5)
Flow Range With 6 To 600rpm Drive (ml/min)	0.36 to 36	1.3 to 130	4.8 to 480	10 to 1000	17 to 1700	23 to 2300
	*The flow range is subject to the motor drive of the pump. Please see Peristaltic Pump specifications for reference.					
Maximum Pressure, Continuous	25psig (1.7bar)		20psig (1.4bar)	15psig (1.0bar)	10psig (0.7bar)	
Maximum Pressure, Intermittent	40psig (2.7bar)		35psig (2.4bar)	20psig (1.4bar)	15psig (1.0bar)	
Maximum Vacuum	26" Hg (660mm Hg)			20" Hg (510mm Hg)		
Suction Lift	29ft H <sub>2</sub> O (8.8m H <sub>2</sub> O)			22ft H <sub>2</sub> O (6.7m H <sub>2</sub> O)		

\* MU-S18 is not compatible with MFU series.



\*Dual Pump Head available accommodate two silicon tubings with the same pump speed at the same time.

## Thermostirrer

The Major Science Thermostirrer is equipped with built-in stirrers on the bottom of each well. Combined with excellent temperature control, the instrument is well-suited for a variety of applications, including synthesis of chemical compounds, denaturation, derivatization, combinatorial chemistry, sample concentration, enzyme assays and process optimization.

### Thermostirrer

#### ▣ Thermostirrer

99-100

Thermostirrer

Remote Thermostirrer Module



\*All images are for reference only, actual products might differ from the images.

\*Please visit our website at [www.majorsci.com](http://www.majorsci.com) for more product selection and detailed information.

\*Technical specification subject to change without notice.

# Thermostirrer Remote Thermostirrer Module

TS-8W  
CM-M0512-001

Major Science Thermostirrers feature leading-edge speed performance and the broadest temperature control range to cover a variety of chemical and biological applications including synthesis of organic compounds, derivatization, drug solubility, protein crystallization and process optimization. Mixing efficiency is maintained uniformly across the sample wells due to independent magnets under each well and thus ensures consistency of experimental results. Furthermore, Major Science designed a remote thermostirrer module for studies that require a thermostatic mixer to function as a part of an automated process such as a polymer viscometers.

The Remote Thermostirrer Module allows you to set your own program with modbus PC connection and integrate with your own manufacture equipment. For more information with this module, please contact Major Science.



CE  
TS-8W



User temperature calibration



Cooling System Connection Port

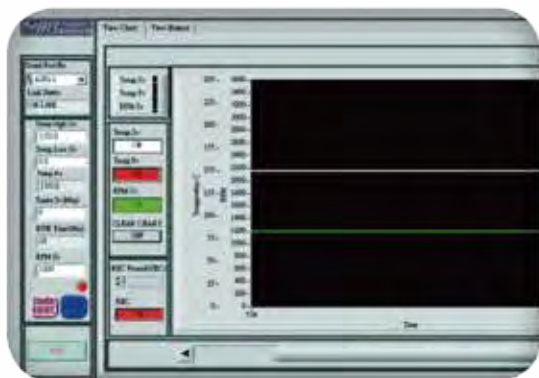

Functional control software package available



CM-M0512-001  
Remote Thermostirrer Module

### Features:

- Microprocessor control with digital performance
- Brushless motor for individual well agitation
- Outstanding temp. control performance up to 200°C
- User temperature calibration
- Customization available
- Well-insulation around casework
- Over temperature protection
- LCD screen & timer (standalone model only)
- Highest stirring speed, 3500rpm in the market





## Specifications

Cat. No.	TS-8W-110	TS-8W-220	CM-M0512-001
Controller	Digital microprocessor controller		
Display	2.6" LCD monochrome display		N/A
Motor	Brushless motor		
Number Of Position	8 wells (2x4) with individual magnetic stirrer or customized		6 wells with individual magnetic stirrer **
Well Diameter	Ø29.5mm, 62mm depth or customized		Ø23mm, 44mm depth **
Stirring Speed	500 - 3500rpm		500 - 2500rpm
Temperature Control Range	5°C above ambient to 200°C		
Temperature Increment	± 0.1°C		
Temperature Uniformity	± 0.7°C @ 150°C		N/A *
Temperature Accuracy	± 0.2°C @ 150°C		± 0.5°C @ 120°C
Temperature Calibration	Yes		
Operating Temperature	Ambient to 40°C		
Timer	99 (hr): 59 (min) / Continuous		
Block Material	PTFE coating with individual magnetic		Anodic treatment without PTFE coating **
Data Logging	RS 232 (Max. 2.5 meter long)		
Safety	Well-insulation around casework		
	Leakage proof for heating chamber		
	Over temperature protection		
Rated Voltage	110V~; 50/60Hz, 6.3A	220V~; 50/60Hz, 3.15A	110V~; 50/60Hz, 6.3A 220V~; 50/60Hz, 3.15A
Dimension (WxLxH)	Approx. 9.1"x11.8"x6.3" (230x300x160mm)		Approx. 5.2"x11.8"x6.3" (132.5x299.5x158.9mm)
Weight	Approx. 18.7lb (8.5kg)		Approx. 11lb(5kg)
Power	600W		
Vessel Diameter	Max. 28.5mm or customized		Max. 22mm **
Communication Port	RS-232		Modbus RTU by RS-232

\* Temperature uniformity would be dependent on the integration to your automation system.

\*\* Customized Specification.

## Ordering Information

Cat. No.	Product Description
TS-8W-110	Thermostirrer 8 wells, 110V~
TS-8W-220	Thermostirrer 8 wells, 220V~
CM-M0512-001	Remote Thermostirrer Module 6wells, 220V~ / 110V~

## Accessories

Cat. No.	Product Description
TS-8W-SW	Functional control and data logging software for Thermostirrer series. Including software CD and cable.



## US Office

19959 Sea Gull Way  
Saratoga, CA 95070  
U.S.A.  
T/ +1-408-366-9866  
F/ +1-408-446-1107

## Taiwan Office

No.19, Ln. 207, Huakang St.  
Bade Dist., Taoyuan City 33464  
Taiwan  
T/ +886-3-3623319 / +886-2-2298-1055  
F/ +886-3-3623133 / +886-2-2299-7871

## Shanghai Office

Room 612, International business exhibition center,  
9300 Hunan Road, Pudong, Shanghai, China  
National toll-free No.:400-823-9177  
T/ +86-21-50795277  
F/ +86-21-50795277

## India Office

D. No. 12-13-99, Satguru Apts. Extn.  
Street. No. 3, Lane No.1, Tarnaka  
Secunderabad – 500 017. India  
T/ +91-40-27001515  
T/ +91-40-27001586



[www.majorsci.com](http://www.majorsci.com)  
[info@majorsci.com](mailto:info@majorsci.com)

